

VACALL™

Operator & Safety Manual

Keep this manual with machine at all times.

ArdVac

S/N VAC0001016 & After

VA0000S4035

*Original Issue,
October 11th, 2007*

**CALIFORNIA PROPOSITION 65
BATTERY WARNING**

**Battery posts,
terminals and related
accessories contain
lead and lead compounds,
chemical known to the
State of California
to cause cancer and
reproductive harm.**

**WASH HANDS
AFTER HANDLING!**

**CALIFORNIA PROPOSITION 65
EXHAUST WARNING**

**Diesel Engine exhaust and
some of its constituents
are known to the State of
California to cause cancer,
birth defects and other
reproductive harm.**

*VacAll is a registered trademark for street sweepers, catch basin
cleaners, sewer cleaners, attachments and other components
manufactured and marketed by VacAll Industries, Inc.*

REVISION LOG

October 11th, 2007 - A - Original Issue of Manual

Read This First

This manual is a very important tool! Keep it with the machine at all times.

The purpose of this manual is to provide owners, users, operators, lessors, and lessees with the precautions and operating procedures essential for the safe and proper machine operation for its intended purpose.

Due to continuous product improvements, VacAll Industries, Inc. reserves the right to make specification changes without prior notification. Contact VacAll Industries, Inc. for updated information.

Operator Qualifications

The operator of the machine must not operate the machine until this manual has been read, training is accomplished and operation of the machine has been completed under the supervision of an experienced and qualified instructor.

Operators of this equipment must possess a valid, applicable driver's license, be in good physical and mental condition. Operator must not be using medication which could impair abilities nor be under the influence of alcohol or any other intoxicant during the work shift.

In addition, the operator must read, understand and comply with instructions contained in the following material furnished with the Vacall.

- This Operator & Safety Manual
- All instructional decals and plates
- Any optional equipment instructions furnished

The operator must also read, understand and comply with all applicable Employer, Industry and Governmental rules, standards and regulations.

If any manual is missing or illegible, get a replacement from your employer, distributor, or from VacAll Industries, Inc.

Modifications

Any modification to VacAll products must be approved by VacAll.

This product must comply with all safety related bulletins. Contact VacAll Industries, Inc. or the local authorized VacAll representative for information regarding safety-related bulletins which may have been issued for this product.

VacAll Industries, Inc. sends safety related bulletins to the owner of record of this machine. Contact VacAll Industries, Inc. to ensure that the current owner records are updated and accurate.

VacAll Industries, Inc. must be notified immediately in all instances where VacAll products have been involved in an accident involving bodily injury or death of personnel or when damage has occurred to personal property or the VacAll product.

FOR:

- Accident Reporting and Product Safety Publications
- Current Owner Updates
- Questions Regarding Product Applications and Safety
- Standards and Regulations Compliance Information
- Questions Regarding Product Modifications

CONTACT:

Product Safety and Reliability Department
Vacall Industries, Inc.
406 Mill Avenue
New Philadelphia, OH 44663
Phone: 330-339-2211
Toll-Free: 1-800-445-4752

Other Publications Available

Parts Manual	VA0000S4034
Service Manual	VA0000S4036

This Page Intentionally Left Blank

TABLE OF CONTENTS

Revision Log

Read This First

Operator Qualifications	b
Modifications	b
Other Publications Available	c

Table of Contents

Section 1 - General Safety Practices

1.1 Hazard Classification System	1-1
Safety Alert System and Safety Signal Words	1-1
1.2 General Precautions	1-1
1.3 Operation Safety	1-2
Electrical Hazards	1-2
Fire/Explosion Hazards	1-2
Burn Hazards	1-3
Crush Hazards	1-4
Slip and Fall Hazard	1-6
Tip Over Hazard	1-6
Job-Site Hazards	1-6
Travel Hazards	1-7
High Pressure Hazards	1-8
Chemical Hazards	1-10
Sewer Gas Hazard	1-11
Chemical Waste Hazard	1-11
Biological Hazards	1-11
Dust Hazard	1-12
1.4 Safety Systems	1-13
1.5 Personal Protection Equipment	1-15

Section 2 - Pre-Operation and Controls

2.1 Pre-Operation Checks & Inspection	2-1
2.2 Safety Decals	2-2
Decal Locations	2-2
2.3 Controls & Indicators	2-4
Cab Control Box & Gauges	2-4
Control Box Ignition	2-6
Auxiliary Engine Control Panel & Gauges	2-7
Boom Controls	2-9
Rear Boom Pendant	2-12
Tailgate Latch (Manual)	2-13

Section 3 - Operation

3.1 Auxiliary Engine Operation	3-1
--------------------------------------	-----

Table of Contents

	Starting Auxiliary Engine	3-1
	Normal Engine Operation	3-5
	Auxiliary Engine Shut Down Procedures.....	3-5
3.2	Advanced Boom Operation	3-6
	Boom Unstore/Store Function	3-6
	Nozzle Auto Swing Function.....	3-7
3.3	Water System.....	3-8
	Drain Valves	3-8
	Intake Water System	3-8
	Water Hand Gun Operation.....	3-8
	Filling the Water Tank.....	3-9
3.4	Unloading Procedure.....	3-10
	Dumping Load/Raising Debris Body.....	3-10
	Cleaning the Debris Body.....	3-12
3.5	End of Shift Shutdown.....	3-13

Section 4 - Lubrication & Maintenance

4.1	General.....	4-1
4.2	Daily Preventative Maintenance.....	4-2
4.3	Weekly Preventative Maintenance	4-5
4.4	Monthly Preventative Maintenance	4-9
4.5	Yearly Preventative Maintenance	4-17
4.6	Lubrication Points.....	4-19

Section 5 - Specifications

5.1	Product Specifications.....	5-1
	Lubricants	5-1
	Hydraulic System	5-1
	Pump	5-1
	Hydraulic fluid	5-1
	Hydraulic Fluid Recommendation.....	5-2
	Capscrew Marking and Torque Values	5-3

Index

SECTION 1 - GENERAL SAFETY PRACTICES

1.1 HAZARD CLASSIFICATION SYSTEM

Safety Alert System and Safety Signal Words



OW00101

DANGER indicates an imminently hazardous situation which, if not avoided, will result in death or serious injury.



OW0021

WARNING indicates a potentially hazardous situation which, if not avoided, could result in death or serious injury.



OW0031

CAUTION indicates a potentially hazardous situation which, if not avoided, may result in minor or moderate injury.

The logo for the CAUTION signal word. It consists of the word "CAUTION" in bold, black, uppercase letters on a white rectangular background with a black border.

CAUTION

OAN0340

CAUTION indicates a potentially hazardous situation which, if not avoided, may result in property damage.

1.2 GENERAL PRECAUTIONS



OW0021

Before operation, read & understand this manual. Failure to comply with the information in this manual could result in machine damage, property damage, personal injury or death.

Section 1 - General Safety Practices

1.3 OPERATION SAFETY

Electrical Hazards

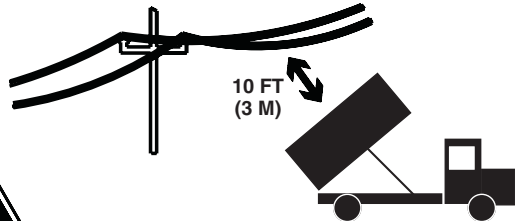
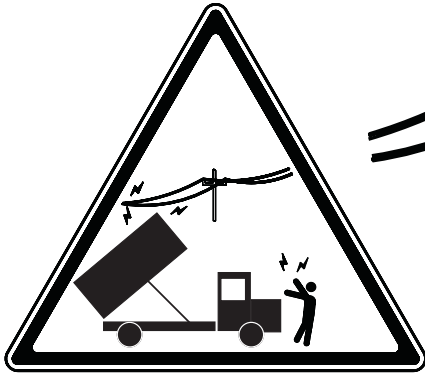

OAN0010

- A potential electric shock hazard exists with the operation of mobile equipment near high voltage power lines. All OSHA and site rules and regulations must be followed.
- Never dump under power lines. End dumps with raised beds will violate the 10' rule.
- Always check for power lines before raising boom or debris body.

Fire/Explosion Hazards



OAN0020

- All fuels, most lubricants and some coolant mixtures are flammable. Smoking in fueling and lubricating areas is prohibited. Also, no smoking is allowed where batteries are charged or where other flammable materials are stored.
 - Battery electrolyte contains acid that could produce an explosion and possibly cause injury.
 - Clean and tighten all electrical connections. Check for frayed or loose electrical wires daily and have them repaired or tightened if needed.
- Report any loose or damaged fuel or oil lines, tubes or hoses to mechanics so repairs can be made. Leaks can cause fires.

Burn Hazards



OAN0030

- Never touch the blower casing or associated piping/accessories after operation.
- Engine coolant is hot and under pressure at operating temperature. The radiator and all lines to heaters of the engine contain hot water or steam and any contact could cause severe burns.
- Check coolant level before heating occurs, and if necessary, only after the engine has been stopped and the filler cap is cool enough to remove with your bare hand. Remove filler cap slowly to relieve pressure.
- Allow components to cool before draining. Do not allow hot oil, coolant or components to contact skin.
- Relieve all pressure in air, oil, fuel or cooling systems before any lines, fittings or related items are disconnected or removed.
- Battery electrolyte contains acid that can cause injury. Avoid contact with skin and eye.

Section 1 - General Safety Practices

Crush Hazards

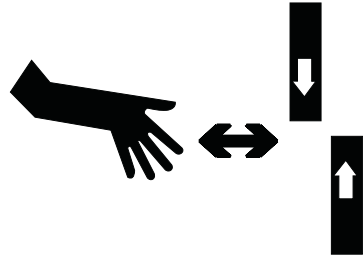
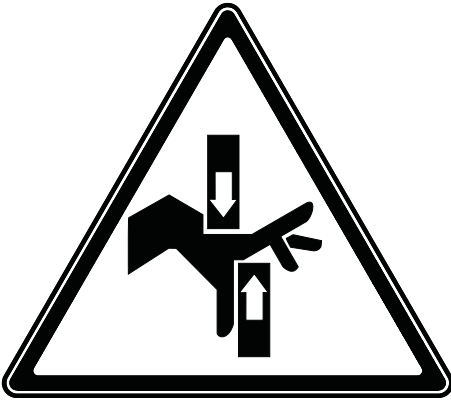

OAC1250

- Do not operate belt driven components with the shroud doors open or belt guards removed. Cover all external moving parts with adequate guards.
- Stay clear of moving parts while engine is running.
- Do not operate the controls of the PTO or other driven equipment from underneath the vehicle while engine is running.
- Never attempt to stop, stall or slow moving components with hands, feet, or any other portion of your body.

Tailgate

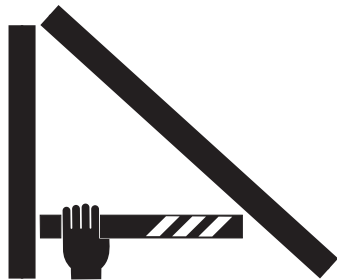

OAN0040

- Never enter the debris body or stand beneath the raised tailgate without first positioning the tailgate safety pin in the hinge bracket. (See page 1-13 for details). Ensure there are no personnel at the rear of the unit when operating the dump system.

Debris Body



- Never leave body raised while vehicle is unattended or while performing maintenance on unit.
- Never work under or near the raised debris body without first securing the safety stand in the stand bracket located on the underside of the body. (See page 1-13 for details).

Section 1 - General Safety Practices

Slip and Fall Hazard



OAN0060

- Always maintain 3-point contact using proper hand holds and steps provided when mounting or dismounting. Never grab control levers or steering wheel when mounting or dismounting machine.
- Repair or replace damaged steps and grab handles.
- Keep grab handles, steps, and walkways free of mud, oil, grease and other foreign material. Replace non-skid surface material as required.

Tip Over Hazard

- Always ensure unit is on firm and level ground before operating the dump system. When dumping, raise the body in steps, allowing the material to dump out in a steady flow.
- People and vehicles cannot be beside debris body while dumping.

Job-Site Hazards

- Always use safety cones.
- Always activate beacons and flashers before job set-up.
- Open manholes and other access openings create risks of trips and falls. Be aware of such locations and do not step in or over them. Ensure that manhole cover and other covers are in place when job is completed.
- Be aware of traffic and pedestrians on the job site. Use extreme caution while moving around the vehicle to avoid contact with other moving vehicles. Before stowing the boom or moving the vehicle, be sure pedestrians are clear of the area.

Travel Hazards

- Ensure unit is roadworthy before driving to and from jobsite.
- Look out for and avoid other personnel, machinery and vehicles in the area. Use a spotter if you **do not** have a clear view.
- **Before moving** be sure of a clear path and **sound horn**.
- When machine is operating or driving on public roadways, **comply with all local, state and federal restrictions**.
- **When driving**, ensure all equipment is properly secured and positioned for maximum visibility and adequate clearances. Know the overall height of the machine.
- **Always check overhead and side clearances** carefully before driving.

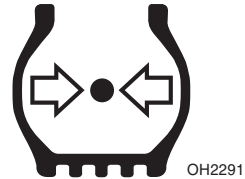

- Always wear seat belt.
- **Maintain proper tire pressure** at all times.

Section 1 - General Safety Practices

High Pressure Hazards

- Never try to open any hatches or doors while the unit is pressurized. Release pressure before attempting to open any door or hatch. Shutting off the pressurizing pump or the power source does not release the pressure. It has to be released manually.
- Do not bend or strike high pressure lines.
- Report any loose or damaged tubes or hoses to mechanics so repairs can be made.

Water Pressure



OW0021

WATER PRESSURE INJURY. In the event of any waterjet injury:

- Seek medical attention immediately. Do not delay!
- Inform the physician of the cause of the injury.
- Tell the physician what type of waterjet project was being performed at the time of the accident and the source of the water.

Operators using or working around high pressure water systems need to take additional precautions including specialized personal protection equipment. Additional information on high pressure water safety and this information is provided by and available as a wallet card from:

WaterJet Technology Association

917 Locust Street, Suite 1100
St Louis, MO 63101-1419
(314) 241-1445
fax (314) 241-1449
e-mail: wjta@wjta.org
website: www.wjta.org

- Use the handgun washdown system for final equipment and job-site clean-ups or cleaning debris build-ups on the inside of body.
- The water handgun operates at high pressure. Never point the water handgun at another individual.
- Always bleed pressure from the water handgun before disconnection from high pressure connection.

Vaccum

An injury caused by vacuum can be serious. The vacuum action must be stopped as quickly as possible at any sign of danger. Seek medical attention immediately.

- Keep vacuum tools and hoses away from face and body. Concentrated vacuum on the body, such as through a hose end, can result in evisceration of organs or the avulsion of limbs. Serious injury or death could result.
- Do not attach hose, pipe or accessories with the vacuum on. Forces from the vacuum can trap fingers, hands and feet with enough force and impact to crush or cut.
- Do not use a bare open hose end for vacuuming. A variety of hose and attachments are available to keep the operator clear of the hose opening.

Section 1 - General Safety Practices

Chemical Hazards

Hydraulic Fluid



OW0950

- **DO NOT** use your hand to check for leaks. Use a piece of cardboard or paper to search for leaks. Wear appropriate equipment to protect yourself from spraying fluid. If fluid is injected into the skin seek medical attention immediately.
- Stop engine and relieve trapped pressure before loosening any hydraulic fitting. Hydraulic oil is under enough pressure that it can penetrate the skin.

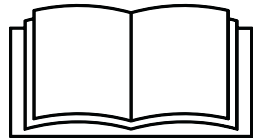

OAC0960

- **DO NOT** attempt to repair or tighten any hydraulic hoses or fittings while the engine is running or when the hydraulic system is pressurized.

Sewer Gas Hazard

- Do not smoke in or around sewer lines, drains or catch basins.

Chemical Waste Hazard

- Many chemicals are illegally dumped in storm drains, catch basins and sewers. To prevent contamination and injury, wear chemical resistant gloves, long sleeves, trousers and safety glasses or face shields.
- Seek immediate medical attention if exposure or contamination is suspected.

Biological Hazards

- Germs and other biological hazards are common in sewers, drains and catch basins. Use gloves, long sleeves and long pants to avoid injury and contamination. Immediately treat all abrasions, cuts and scratches for contamination. Get medical attention for injuries associated with cleaning sewers, drains and catch basins if biological contamination is suspected.

Section 1 - General Safety Practices

Dust Hazard



OAC0660

- Repeated or substantial breathing of hazardous dusts, including crystalline silica, could cause fatal or serious respiratory disease including silicosis. Concrete, masonry, many types of rock, and various other materials contain silica sand. California lists respirable crystalline silica as a substance known to cause cancer. Operation of this equipment under certain conditions may generate airborne dust particles that could contain crystalline silica. In those conditions personal protective equipment including an appropriate respirator must be used. If excessive dust is generated, a dust collection or suppression system should also be used during operation.

1.4 SAFETY SYSTEMS

Body Support

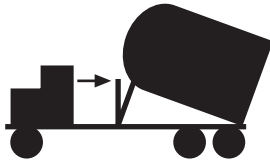

OAN0070

When maintenance is performed that requires working under a raised body, the raised EMPTY body must be supported by the safety stands provided. These are safety stands only; not lifting devices. They must be used in conjunction with the hoist cylinder, not in place of.

Never support a loaded body with the safety stands. Never try to remove a hoist cylinder, leaving the body supported by the safety stands. To use the safety stands:

1. Remove locking pins from both safety stands.
2. Pull the ripcord located on the passenger side of the machine below the body. This will release both safety stands from their stored position.
3. Raise the body until the safety stands slide into the anchor welds.
4. Place locking pins through the safety stand and anchor weld on each side of machine.

CAUTION

OAN0340

Do not activate body hoist while safety stands are secured by locking pins. Failure to do so will cause machine damage.

Section 1 - General Safety Practices

Rear Door Support



OAN0080

When maintenance is to be done inside a body or on the rear door that requires it to remain open, use the rear door support provided.

1. Unlatch tailgate. See page 2-13 for details.
2. Attach the tailgate lift chain to the rear boom. Use the rear boom pendant (see page 2-12 for details) to raise boom and open tailgate.
3. Lower the rear door support located on the inside of the rear door into the hinge bracket welded on body.

1.5 PERSONAL PROTECTION EQUIPMENT

Wear all the protective clothing and personal safety devices issued to you or called for by job conditions. You may need:

- Hard hat
- Safety shoes
- Safety glasses, goggles or face shield
- Heavy gloves (chemical resistant)
- Hearing protection
- Reflective clothing
- Wet weather gear
- Respirator or filter mask

Wear adequate clothing for the job conditions.

Always know where to get assistance in the case of an emergency. Know where to find and how to use a first aid kit and fire extinguisher/fire suppression system.

This Page Intentionally Left Blank

SECTION 2 - PRE-OPERATION AND CONTROLS

2.1 PRE-OPERATION CHECKS & INSPECTION

Note: Complete all required maintenance before operating unit.



OW0021

FALL HAZARD: Use extreme caution when checking items beyond your normal reach. Use an approved ladder. Failure to comply could result in death or serious injury.

Walk around inspection must be performed at beginning of each work shift or at each change of operator.

1. Make sure the Control Box Ignition is in the “OFF” position. See page 2-4 for location.
2. Make sure the Engine Run/Shut Down switch is in the “SHUT DOWN” position. See page 2-7 for location.
3. Ensure all Safety decals are legible and in place. Clean or replace as required.
4. Check for leaks on and around the unit (hydraulic cylinders, valves and fittings). Before removing filler caps or fill plugs, wipe all dirt and grease away from the ports. If dirt enters these ports, it can severely reduce component life.
5. Ensure bolts and fittings are tight and not worn. Check all visible welds for cracks.
6. Inspect the inside of the debris body to make sure the filter screens are properly installed and clean, that the debris body is completely empty, and the tail gate seal area is clean.
7. Close all water system drain valves.
8. Make sure the debris body is completely lowered and the intake is properly secured.
9. Inspect nozzles, linkages, tubes, hoses and belts for wear or damage. Replace if needed.
10. Check the tailgate and debris body props for damage. If damage is found, do not operate machine until proper repairs are made.
11. Make sure all equipment and accessories are properly and securely stored.
12. Check all fluid levels and refill as needed.

If service or repairs are required, place “Do Not Operate” tag on cab control box ignition, auxiliary engine control panel and steering wheel of vehicle and remove keys.

Section 2 - Pre-Operation and Controls

2.2 SAFETY DECALS

Ensure all **DANGER**, **WARNING**, **CAUTION** and instructional decals are legible and in place. Clean and replace as required.

Decal Locations

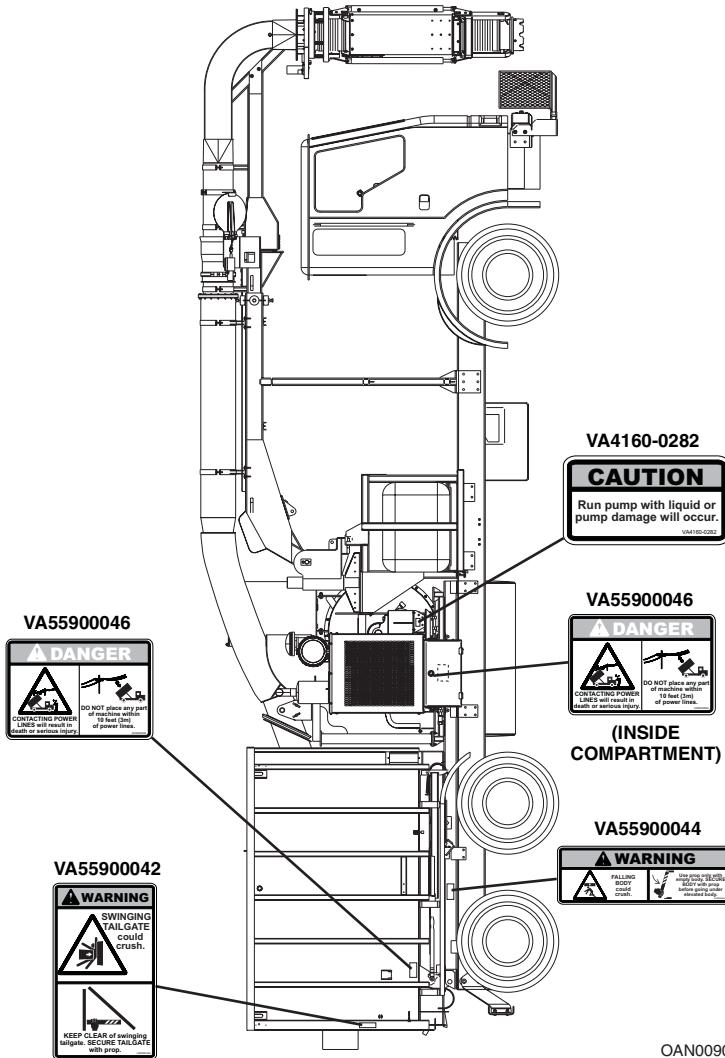

OAN0090

Section 2 - Pre-Operation and Controls

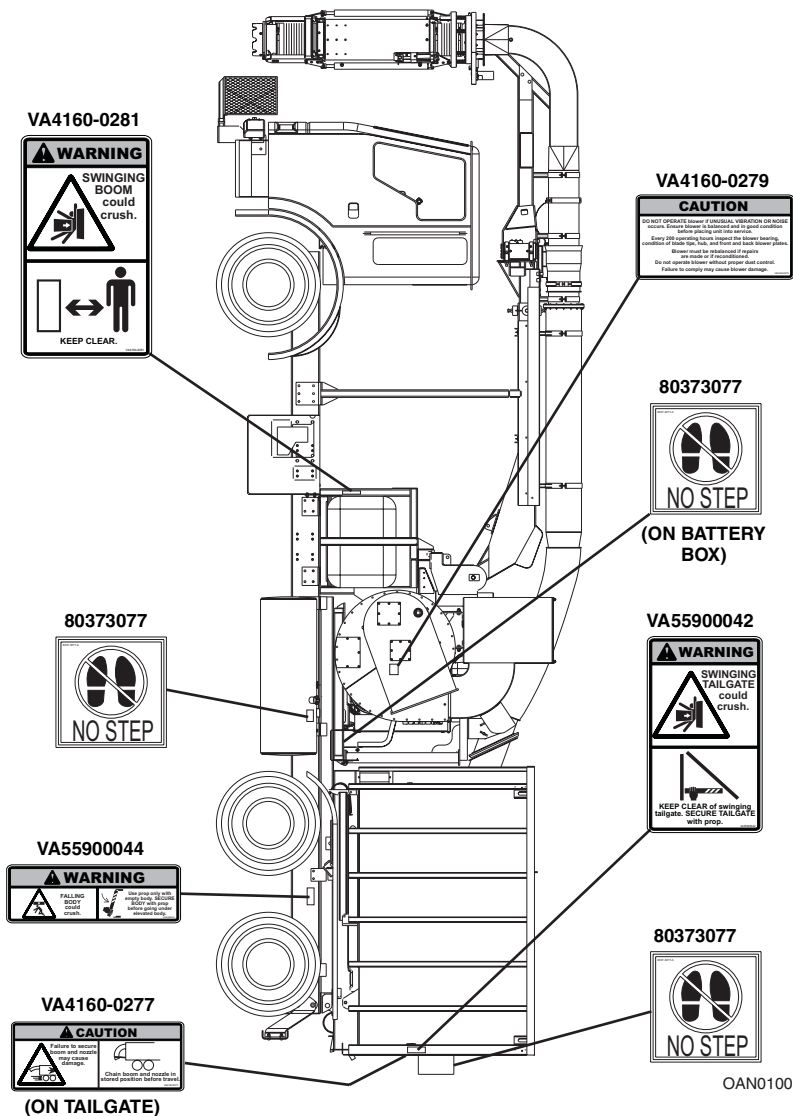

Section 2 - Pre-Operation and Controls

2.3 CONTROLS & INDICATORS

Cab Control Box & Gauges

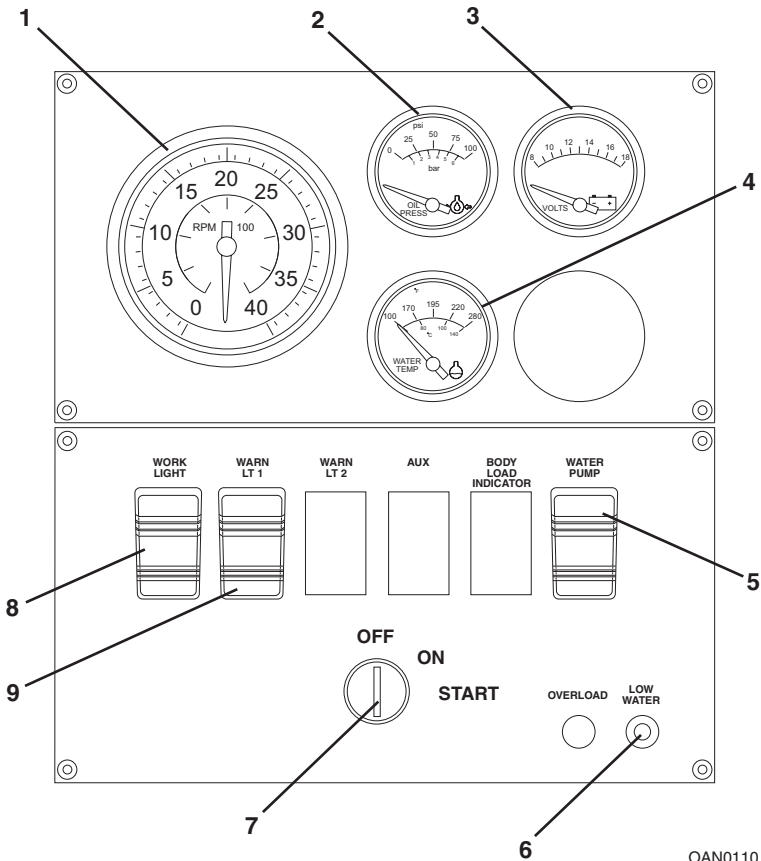

OAN0110

Section 2 - Pre-Operation and Controls

1. Tachometer: Indicates auxiliary engine rpm.
2. Engine Oil Pressure Gauge: Indicates auxiliary engine oil pressure. Auxiliary engine will shut down if pressure falls below factory preset pressure.
3. Voltmeter: Indicates voltage output of auxiliary engine alternator.
4. Coolant Temperature Gauge: Indicates auxiliary engine coolant temperature. Auxiliary engine will shut down if coolant temperature rises above factory preset temperature.
5. Water Pump: Controls activation of water pump. To engage the water pump, press switch to the "ON" position. To disengage water pump, press switch to the "OFF" position.
6. Low Water Indicator: Indicator light will activate if water level in tank falls below preset level.
7. Ignition: Key Activated. See page 2-6 for details.
8. Work Lights: On/Off switch.
9. Warning Light 1: On/Off switch.

Section 2 - Pre-Operation and Controls

Control Box Ignition

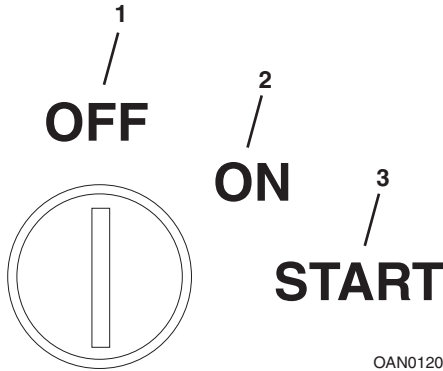

1. OFF: Engine off.
2. ON: Prohibits rotating key switch to position 3 in the event the engine does not start. Rotate the key to position 1 then back to position 3 to re-engage the starter.
3. START: Engine start.

Auxiliary Engine Control Panel & Gauges

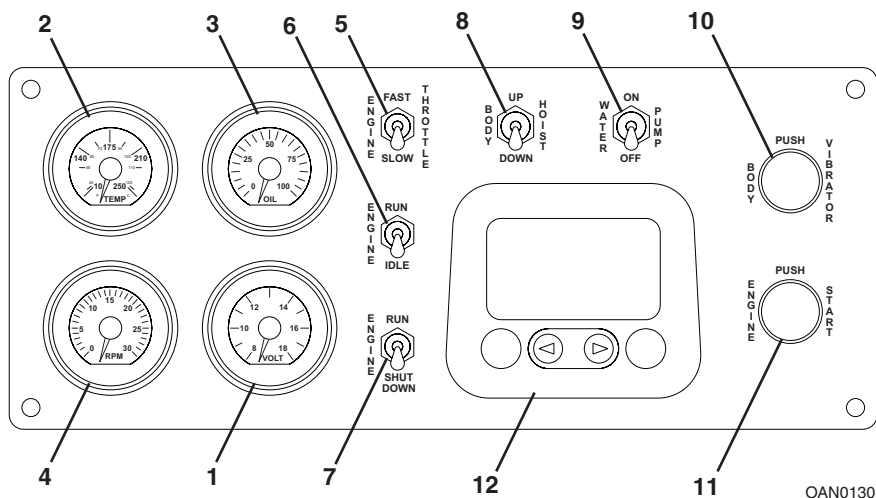

OAN0130

1. **Tachometer:** Indicates auxiliary engine rpm.
2. **Engine Oil Pressure Gauge:** Indicates auxiliary engine oil pressure. Unit will shut down if engine pressure falls below factory preset pressure.
3. **Voltmeter:** Indicates voltage output of auxiliary engine alternator.
4. **Coolant Temperature Gauge:** Indicates auxiliary engine coolant temperature. Unit will shut down if coolant temperature rises above factory preset temperature.
5. **Engine Throttle:** Increases or decreases auxiliary engine throttle speed. Range of throttle speed is determined by position of Engine Run/Idle switch (6). Press and hold switch in "FAST" position to increase auxiliary engine throttle speed. Press and hold switch in "SLOW" position to decrease auxiliary engine throttle speed. Release switch when desired throttle speed is reached.
6. **Engine Run/Idle:** Switch in "IDLE" position allows engine throttle range of approximately 600 to approximately 1200 rpm. When switch is moved to "RUN" position, the engine throttle range is from the rpm value when switch was moved to the "RUN" position to approximately 2070 rpm.
7. **Engine Run/Shut Down:** Switch must be in "RUN" position to start auxiliary engine. Press switch to "SHUT DOWN" position to shut down running auxiliary engine
8. **Body Hoist:** Raises and lowers debris body. Press and hold switch in "UP" position to raise debris body. Press and hold switch in "DOWN" position lower debris body. Release switch when desired debris body position is reached.

Section 2 - Pre-Operation and Controls

9. Water Pump: Controls activation of water pump. To engage the water pump, press switch to the "ON" position. To disengage water pump, press switch to the "OFF" position.
10. Body Vibrator: Depress and hold button to activate debris body vibrator. Release button to stop body vibrator.

CAUTION

OAN0340

Damage to the debris body may occur if Body Vibrator button is depressed longer than 5 seconds.

11. Engine Start: Depress button to start auxiliary engine.
12. Engine Diagnostic Display

Boom Controls

Joystick Enclosure Assembly

The Joystick Enclosure Assembly can be operated from the truck cab or remotely. To operate remotely, unplug the enclosure assembly from the chassis cab. Using the provided extension cord, plug one end of the cord into the enclosure assembly and the other end into the plug located on the front bumper on the passenger side of the truck.

Note: *The auxiliary engine will not activate if joystick enclosure assembly is not plugged in. The auxiliary engine, if running, will shut down if joystick enclosure assembly is unplugged.*

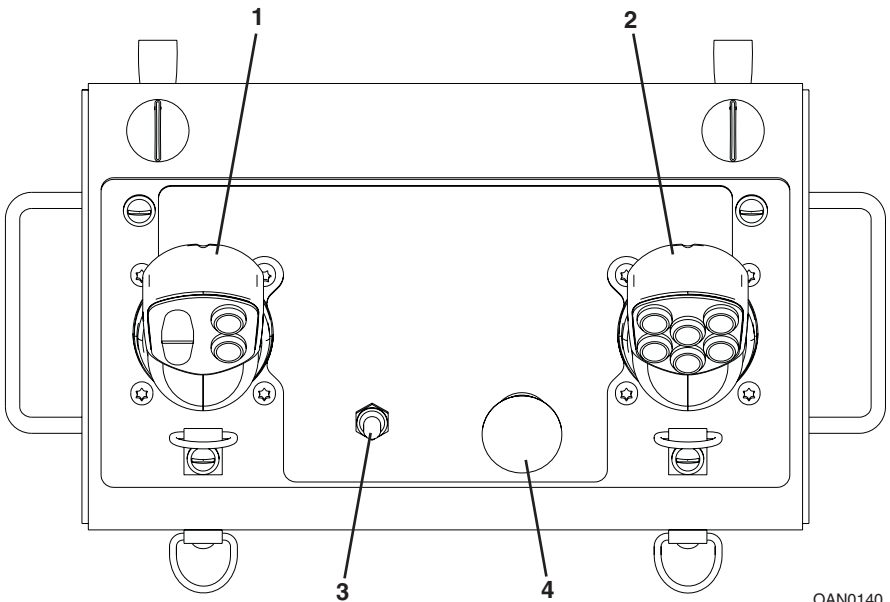

1. Left Hand Joystick: See page 2-10 for details.
2. Right Hand Joystick: See page 2-11 for details.
3. Nozzle Auto Swing Function: See page 3-6 for details.
4. Emergency Stop: Must be in fully raised position to allow auxiliary engine to start. Press and release to shut down running auxiliary engine.

Section 2 - Pre-Operation and Controls

Left Hand Joystick Functions

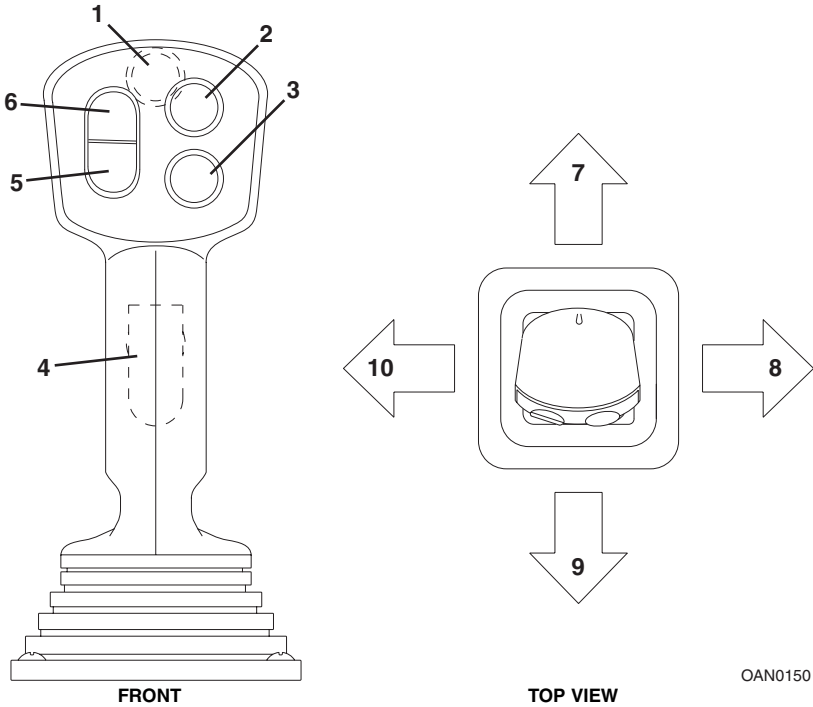

OAN0150

Note: Joystick functions will not activate without joystick activation button (item 4) held down.

1. Auto Swing Set: See page 3-6 for details.
2. Nozzle Rotate Right: Press and hold button to rotate nozzle right.
3. Nozzle Rotate Left: Press and hold button to rotate nozzle left.
4. Joystick Activation: Button must be depressed for joystick functions to activate.
5. Nozzle Retract: Press and hold button to retract nozzle.
6. Nozzle Extend: Press and hold button to extend nozzle.
7. Swing Nozzle End Left: Move joystick forward to swing nozzle end left.
8. Swing Nozzle Right: Move joystick right to move nozzle right.
9. Swing Nozzle End Right: Move joystick back to swing nozzle end right.
10. Swing Nozzle Left: Move joystick left to move nozzle left.

Right Hand Joystick Functions

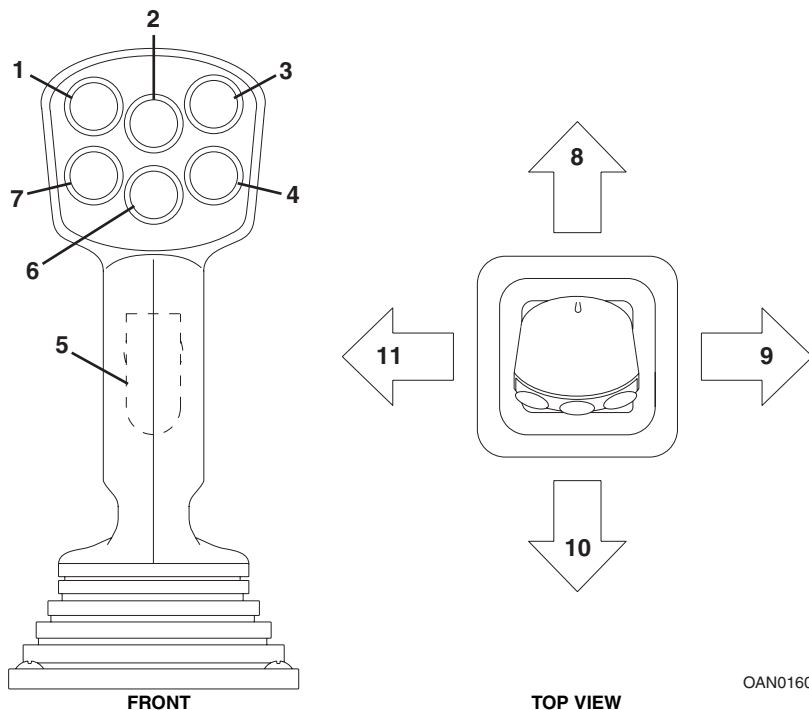

OAN0160

Note: Joystick functions will not activate without joystick activation button (item 5) held down.

1. Store Boom: See page 3-8 for details.
2. Engine Throttle Up: Press and hold button to increase auxiliary engine throttle speed.
3. Boom Extend: Press and hold button to extend boom.
4. Boom Retract: Press and hold button to retract boom.
5. Joystick Activation: Button must be depressed for joystick functions to activate.
6. Engine Throttle Down: Press and hold button to decrease auxiliary engine throttle.
7. Unstore Boom: See page 3-8 for details.
8. Lower Boom: Move joystick forward to lower boom.
9. Boom Right: Move joystick right to swing boom right.
10. Raise Boom: Move joystick back to raise boom.
11. Boom Left: Move joystick left to swing boom left.

Section 2 - Pre-Operation and Controls

Rear Boom Pendant

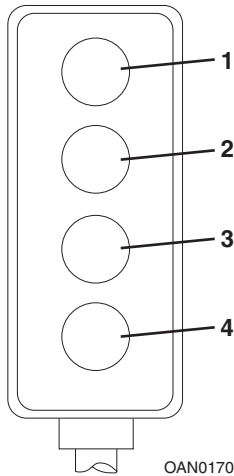

Note: Functions 1 and 2 can be used without the auxiliary engine running. The emergency stop button on the Joystick Control Enclosure must be raised, and the Control Box Ignition must be in the “ON” position.

1. Boom Up: Raises rear boom.
2. Boom Down: Lowers rear boom.
3. Throttle Up: Increases auxiliary engine throttle.
4. Throttle Down: Decreases auxiliary engine throttle.

Tailgate Latch (Manual)

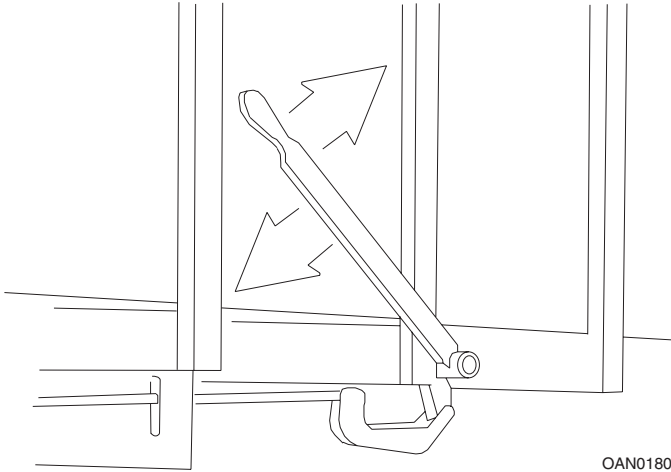

OAN0180

This handle mechanically latches or unlatches the tailgate. Pull the handle toward the rear of the machine to latch the tailgate. Pull the handle toward the front of the machine to unlatch tailgate.

This Page Intentionally Left Blank

SECTION 3 - OPERATION

3.1 AUXILIARY ENGINE OPERATION

Starting Auxiliary Engine

The auxiliary engine can be started from inside the cab or from outside the cab. The following steps show the procedure for both methods.

Inside of Cab:

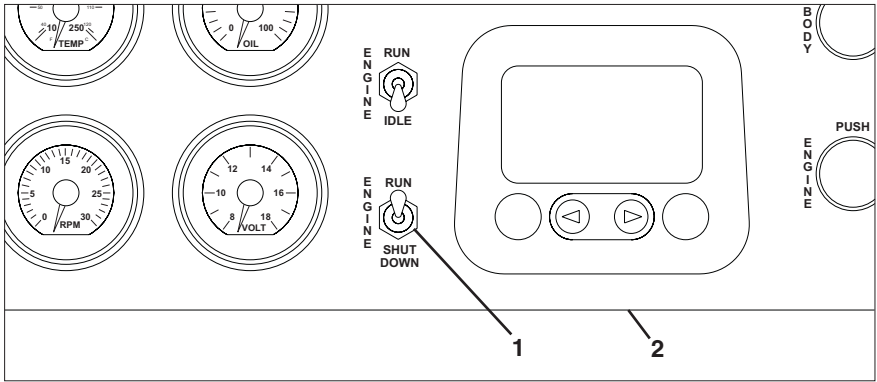

OAN0190

1. Move the Engine Run/Shut Down switch (1) to the "RUN" position on the Engine Control Panel (2).

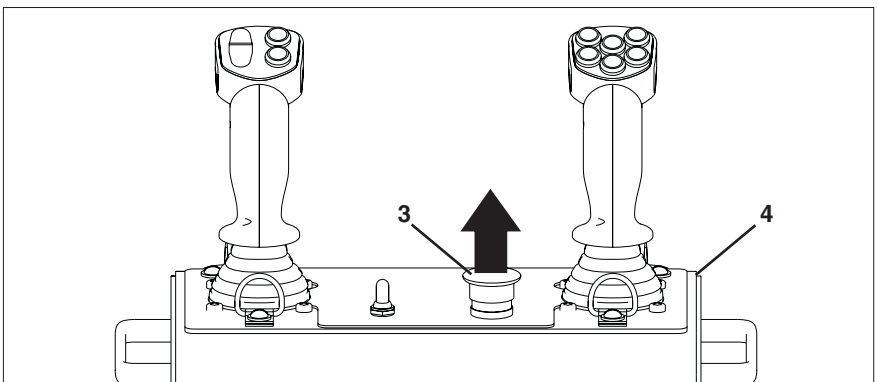

OAN0200

2. Pull the Emergency Stop Button (3) on the Joystick Enclosure Assembly (4) to the fully raised position.

Section 3 - Operation

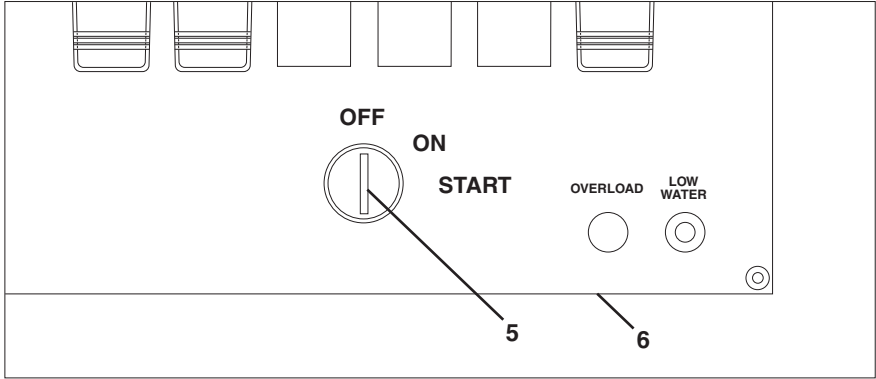

OAN0210

3. Turn ignition key (5) on Cab Control Box (6) to "START" position and release.

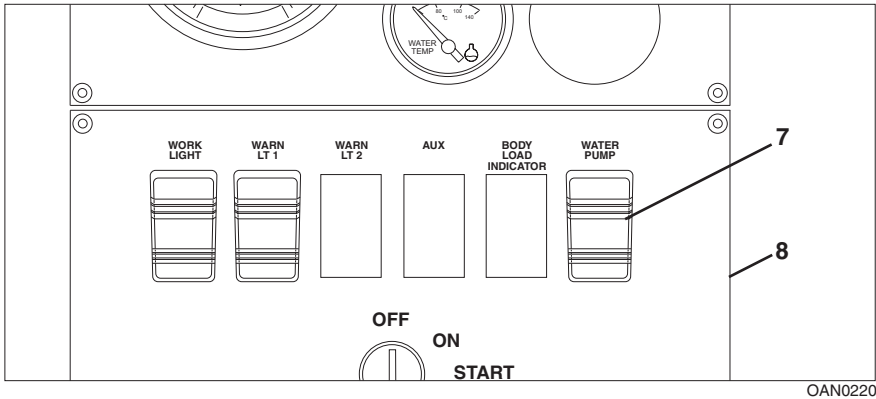

OAN0220

4. Press Water Pump switch (7) on Cab Control Box (8) to the "ON" position.

CAUTION

Never operate water pump without water in the water tank. Pump damage may occur.

OAN0340

Outside of Cab:

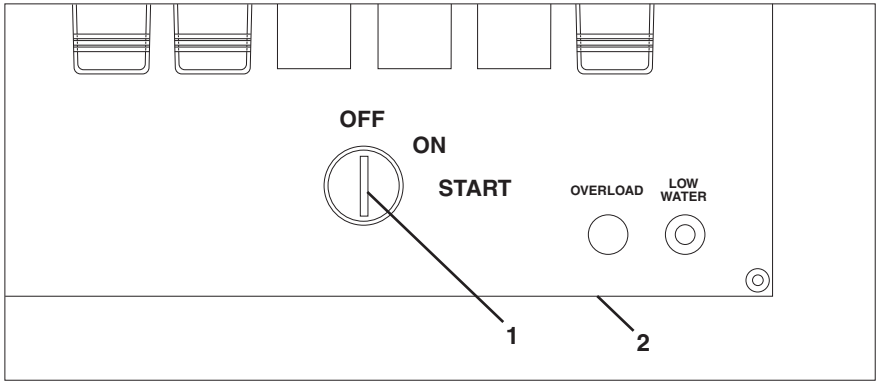

OAN0230

1. Turn ignition key **(1)** on Cab Control Box **(2)** to “ON” position.

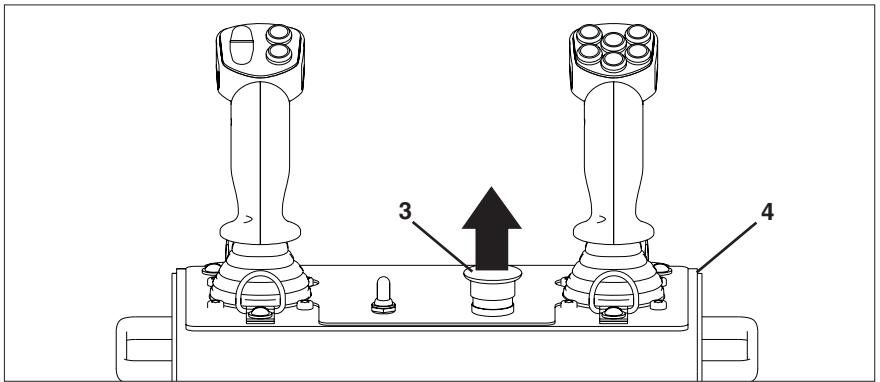

OAN0200

2. Pull the Emergency Stop Button **(3)** on the Joystick Enclosure Assembly **(4)** to the fully raised position.

Section 3 - Operation

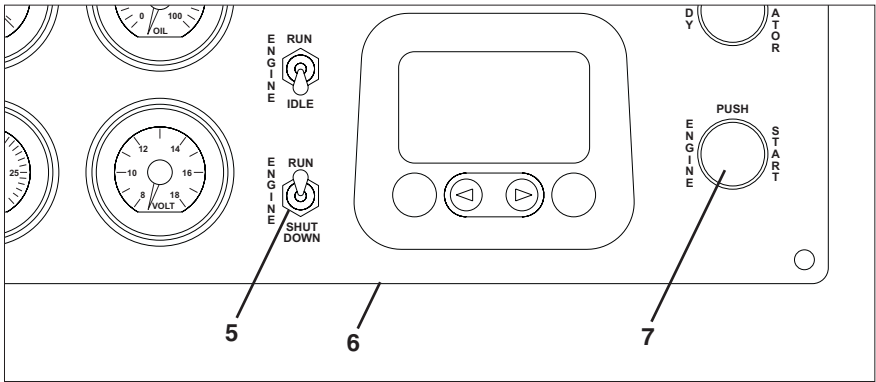

OAN0240

3. Move the Engine Run/Shut Down switch (5) to the "RUN" position on the Engine Control Panel (6). Press and release Engine Start Button (7).

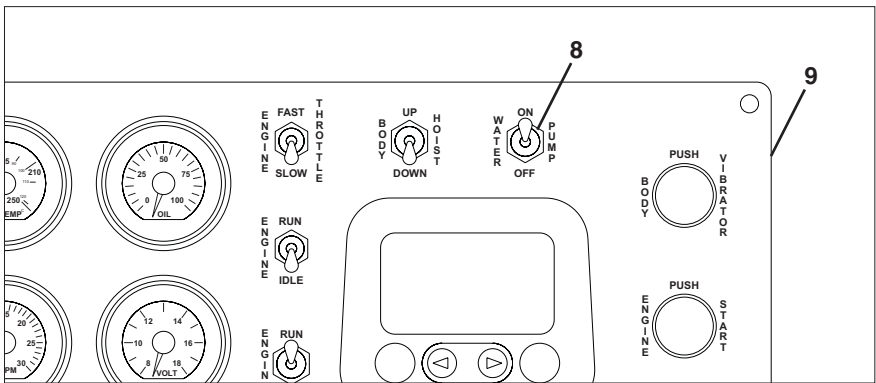

OAN0250

4. Move the Water Pump On/Off switch (8) to the "ON" position on the Engine Control Panel (9).



Never operate water pump without water in the water tank.

OW0031

Normal Engine Operation

- Observe gauges frequently to be sure all engine systems are functioning properly.
- **Be alert for unusual noises or vibration.** If an unusual condition is noticed, park machine in a safe position and perform shut-down procedure. See Auxiliary Engine Shutdown Procedures. Report condition to your supervisor or maintenance personnel.
- **Avoid prolonged idling.** If the engine is not being used, turn it off.

Auxiliary Engine Shut Down Procedures

The Auxiliary Engine can be shut down at any time using any of the following procedures.

From Inside Cab:

1. Bring engine to an idle and disengage water pump.
2. Turn ignition key on Cab Control Box to the “OFF” position.
3. Move Engine Run/Shut Down switch to the “SHUT DOWN” position on the Engine Control Panel.

Outside of Cab:

1. Bring engine to an idle and disengage water pump.
2. Move Engine Run/Shut Down switch to the “SHUT DOWN” position on the Engine Control Panel.
3. Turn ignition key on Cab Control Box to the “OFF” position. Failure to do so can drain battery power.

Joystick Enclosure Assembly (Emergency Only):

1. Press and release the Emergency Stop button on the Joystick Enclosure Assembly.
2. Move Engine Run/Shut Down switch to the “SHUT DOWN” position on the Engine Control Panel.
3. Turn ignition key on Cab Control Box to the “OFF” position. Failure to do so can drain battery power.

Note: Steps 2 and 3 can be completed in any order.

CAUTION

OAN0340

Failure to bring engine to an idle and disengage the water pump before auxiliary engine shut down may damage components.

Section 3 - Operation

3.2 ADVANCED BOOM OPERATION

Boom Unstore/Store Function

Unstoring the Boom:

1. Raise the boom enough to allow clearance of the boom rest.

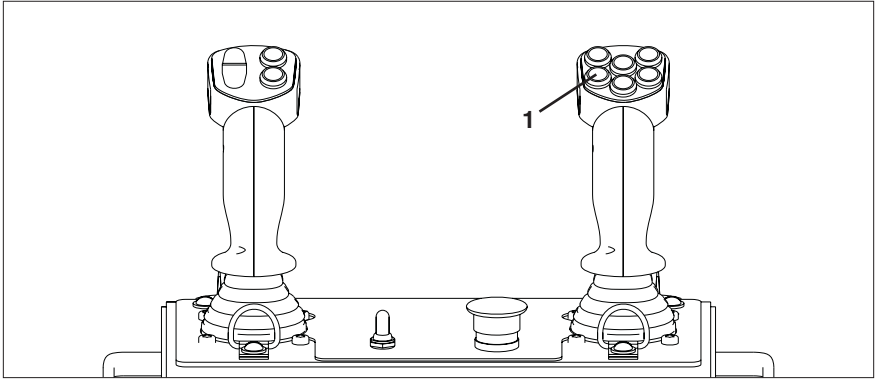

OAN0260

2. Press and hold Unstore Boom button (1) until boom is in operational position.

Storing the Boom:

1. Retract boom completely.
2. Straighten and position nozzle vertically.
3. Raise the boom enough to allow clearance of the boom rest.

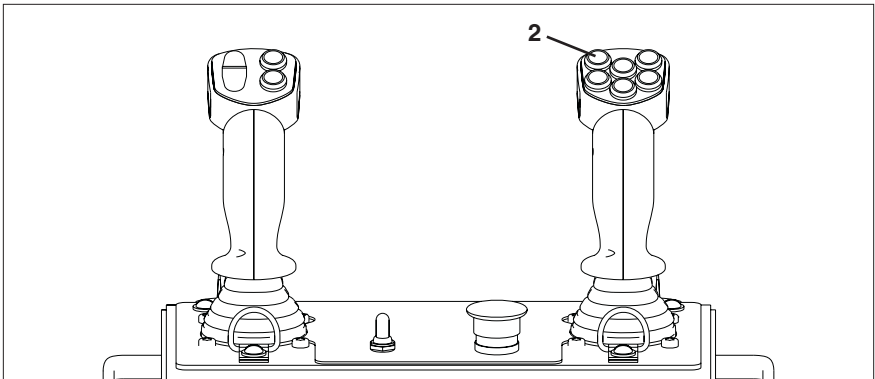

OAN0270

4. Press and hold Store Boom button (2) until boom is in stored position and boom cover closes.
5. Lower boom to boom rest.

Nozzle Auto Swing Function

When this feature is activated, the nozzle automatically swings back and forth.

The operator uses the joystick to move the nozzle to the left and right to select start and stop points within the swing range. The nozzle will then automatically swing between the pre-selected points.

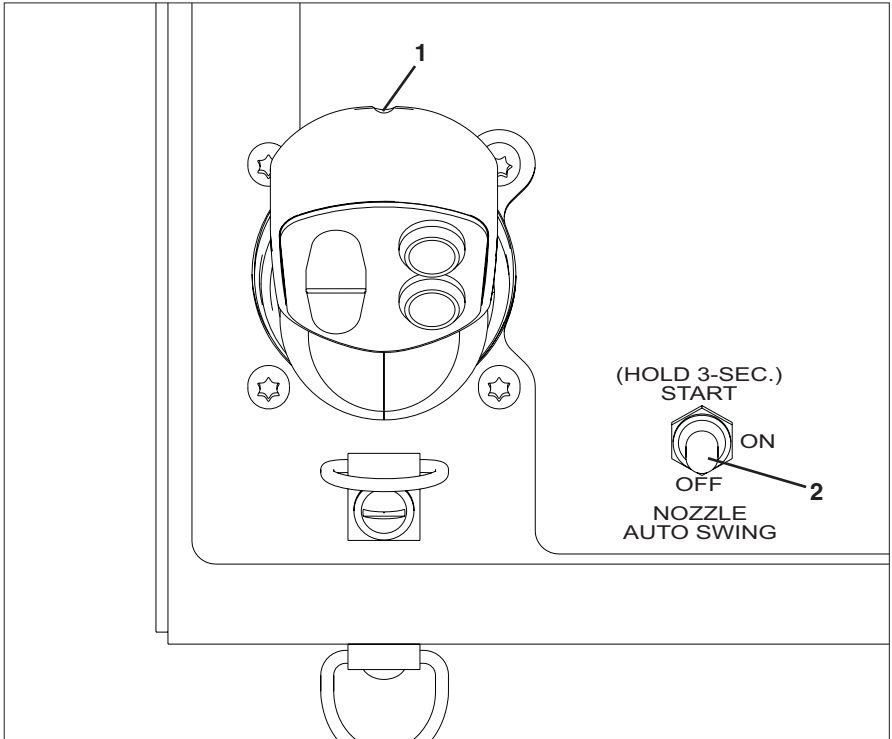

OAN0280

Set the auto swing function as follows:

1. Move the nozzle auto swing function switch **(2)** to the "ON" position.
2. Swing nozzle to desired start point and press the auto swing set button **(1)**.
3. Swing nozzle to the desired stop point and press the auto swing set button **(1)**.
4. Press and hold the nozzle auto swing function switch **(2)** in the "START" position for approximately 3 seconds and release.
5. To stop the auto swing feature, move the nozzle auto swing function switch **(2)** to the "OFF" position or press the auto swing set button **(1)**.

Section 3 - Operation

3.3 WATER SYSTEM

Drain Valves

There are 3 water drain valves located on the Ardvak.

- Below the tailgate at rear of machine
- At water pump (“Y” strainer)
- Right side of machine behind front bumper.

Intake Water System

The water pump supplies water to the vacuum intake elbow as an aid for dust suppression and to ease debris transfer through the intake hose. Water is injected into the elbow through two ports. Water flow to the elbow may be metered by use of the ball valve located by the water pump.

Water Hand Gun Operation

The water pump draws water from the water tank and supplies water pressure at the hand gun. The hand gun is used for general clean up and to clean out the debris body.

1. Turn off auxiliary engine and ensure park brake is set in chassis.
2. Close all drain valves and valve located on hand gun.
3. Connect hand gun hose to valve located below the tailgate at rear of machine or right side of machine behind front bumper.
4. Start the auxiliary engine and turn Water Pump switch on Engine Control Panel to the “ON” position.
5. Adjust the auxiliary engine speed, as needed, to achieve desired water volume and pressure.

Filling the Water Tank

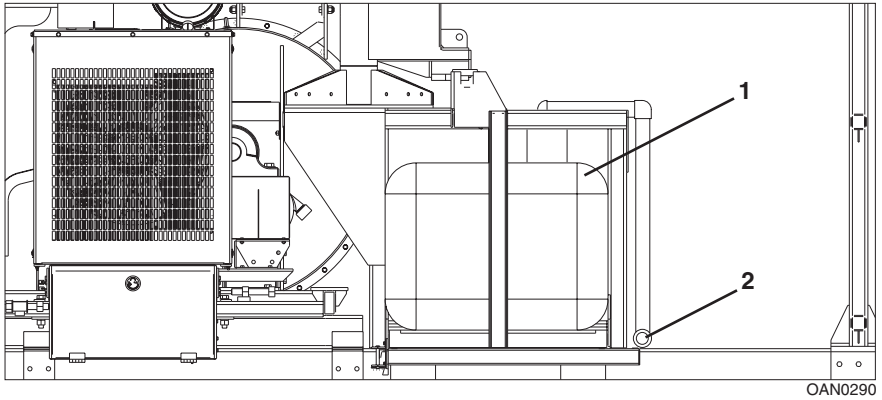

1. Connect the water tank fill tube **(2)** located on the right hand side of unit on the water tank **(1)** to a clean source of pressurized water using supplied fill hose.
Note: *If a fire hydrant is to be used as a water source, flush the hydrant until the water is visibly clear before filling tank.*
2. Slowly open the water source's valve and fill the tank as needed. When the water reaches the desired level, close the water source's valve and remove and store fill hose.

CAUTION

OAN0340

Some water systems operate at high pressures. Over-pressurizing the fill hose may cause it to rupture.

CAUTION

OAN0340

Do not fill water tank or store water in the tank if the ambient outside temperature is below 32° F (0° C). Water tank damage may occur.

Section 3 - Operation

3.4 UNLOADING PROCEDURE

Dumping Load/Raising Debris Body

The Ardvak is designed to dump the material collected in the debris body similar to a traditional dump truck. The material will exit the rear of the debris body when the tailgate is unlatched and suspended by the rear boom and the body raised.

The unit must be positioned on a solid, level surface that is able to support the machine.

1. Position the unit so the material being unloaded will not flow back under the unit when the tailgate is opened and the debris body is raised.
2. Shut off Auxiliary Engine. See page 3-5 for details.
3. Fill the water tank (if needed). See page 3-9 for details.
4. Connect the hand gun hose to valve located below the tailgate at rear of machine.

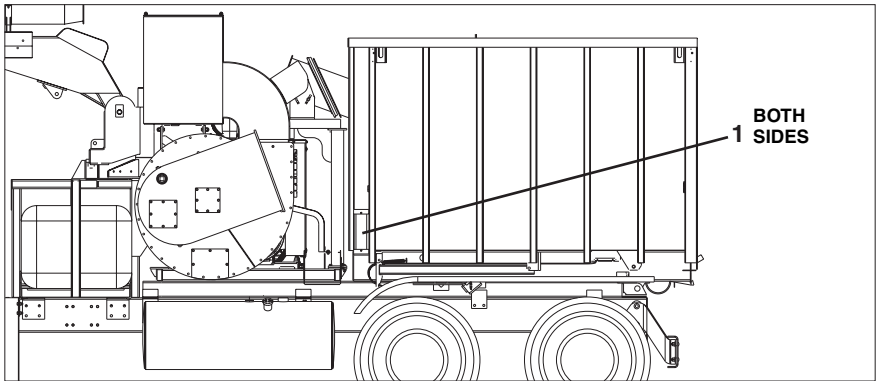

OAN0300

5. Remove both air chamber covers **(1)** and store them in a secure location.
6. Attach the tailgate lift chain to the rear boom.
7. Start Auxiliary Engine and bring to approximately 1200 rpm. See page 3-1 for details.
8. Drain liquid from debris body using sump hose (and valve, if equipped).
9. Unlatch the tailgate. See page 2-13 for details.
10. Once the liquid or solid material has fallen out, raise tailgate using rear boom pendant.

CAUTION

OAN0340

Be sure both tailgate latches have dropped away from both tailgate latch pins before raising tailgate.

TAILGATE
LATCHES

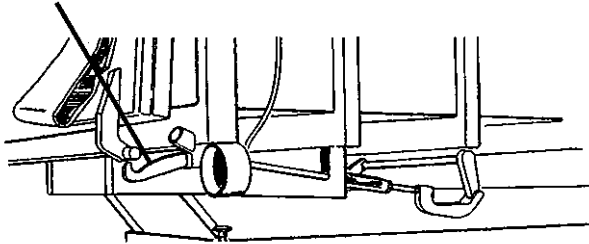

OAN0310

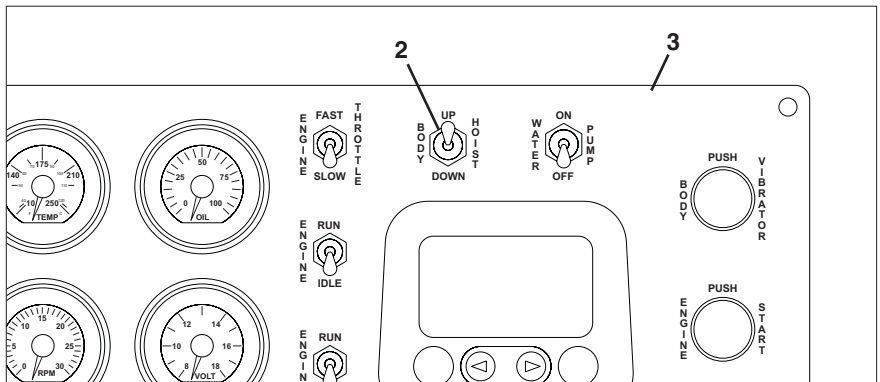

OAN0320

- Press and hold Body Hoist switch (2) on the Engine Control Panel (3) in the "UP" position until the body is in the fully raised position.

⚠ DANGER

OW00101

Be sure the unit is on a solid, level surface and that there is sufficient overhead clearance before the debris body is raised.

- Raise body support safety stands. See page 1-13 for details.
- Clean the debris body. See page 3-12 for details.

Section 3 - Operation

Cleaning the Debris Body

1. Secure the tailgate using the tailgate props. See page 1-13 for details.
2. With the body in the raised position, wash out the entire debris body with the water hand gun. Start at the upper front corner and work downward and toward the rear of the body. Change sides and repeat the procedure. **Note:** *If the unit is to be used immediately after dumping, then it is necessary to clean only the screens, tailgate seal area and the air chambers.*
3. Raise debris body enough to release/store body support safety stands.

CAUTION

OAN0340

Attempting to lower debris body without releasing/storing the body support safety stands first will cause serious machine damage.

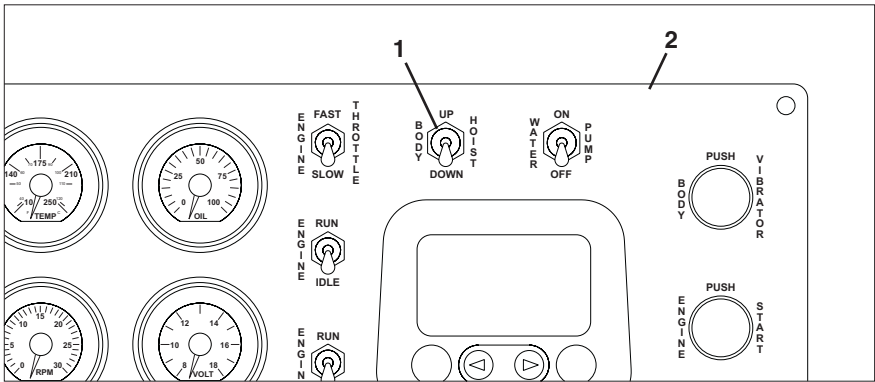

OAN0330

4. Press and hold Body Hoist switch (1) on the Engine Control Panel (2) in the "DOWN" position until the body is in the fully lowered position.

CAUTION

OAN0340

When the debris body reaches fully lowered position, IMMEDIATELY release Body Hoist switch. Failure to do so can cause machine damage.

5. Thoroughly clean out the air chamber(s) and roof area. **Note:** *If the unit is to be used immediately after dumping, replace air chamber covers after cleaning.*
6. Remove rear door support and lower the tailgate with rear boom pendant. Relatch tailgate.
7. Shut off auxiliary engine. See page 3-5 for details.
8. Disconnect and store water hand gun.

3.5 END OF SHIFT SHUTDOWN

Shutting down the unit at the end of a shift consists of completely draining the water system and opening the debris body to allow air to circulate through it.

1. Be sure the unit is thoroughly cleaned as described on page 3-12.
2. Open all water system drain valves.
3. Open the tailgate latch. Remove the air chamber covers and store them in a secure location.
4. If the unit is to be stored longer than overnight, the tailgate should be propped open with the rear door support and the debris body partially raised and blocked.
5. Perform suggested maintenance as described in the service manual.

This Page Intentionally Left Blank

SECTION 4 - LUBRICATION & MAINTENANCE

4.1 GENERAL

The Vacall is designed for long periods of efficient, uninterrupted operation. Careful attention to proper preventative maintenance as described in this section will insure and extend trouble free operation of the unit. Particular attention to correct lubrication of the unit, routine cleaning, and maintenance of the hydraulic system are the most vital areas of preventative maintenance required. The objective of preventative maintenance is to anticipate and prevent operation difficulties before they require extended down time for costly repairs.

Prepare and adhere to a maintenance schedule. Keep detailed records of all maintenance performed. Regularly inspect operating and maintenance records for deviations from normal operating conditions. Analyze the records for indications of potential trouble.

Note: *This section provides general operator lubrication and maintenance information. Refer to Service Manual VA0000S4036 for detailed maintenance, lubrication and service information.*

Section 4 - Lubrication & Maintenance

4.2 DAILY PREVENTATIVE MAINTENANCE

Each day perform the following maintenance:



OW0021

Never enter the Vacall body until the blower is disengaged and the truck and auxiliary engines are off with the keys removed and "Do Not Operate" tags on the unit. Before entering the body, secure tailgate prop in locked position.

1. Inspection

Perform the pre-operational inspection described in the Operator & Safety manual.

2. Daily Cleaning:

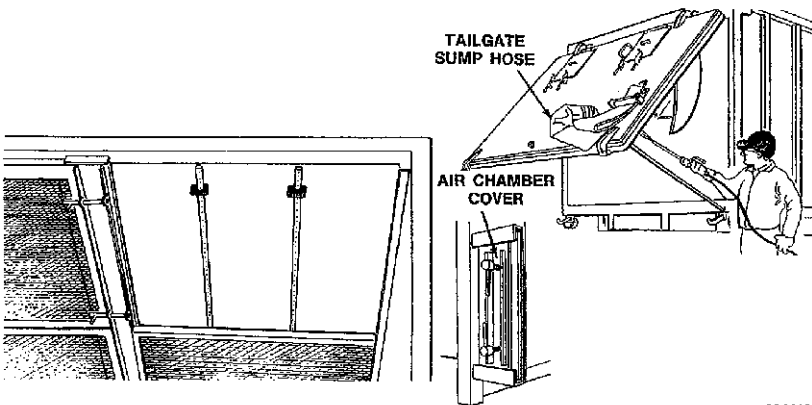

MAN0040

- a. Lower the hinged front baffle inside the body.
- b. Wash the inside of the vacuum body including behind the front baffle and the filter screens.
- c. Remove both clean-out covers from the front air chamber, flush out any accumulated material. Replace covers.
- d. Drain water from hose on the tailgate sump.
- e. After the cleaning is completed, start the Vacall engine, engage the blower fan and run the unit for a short time to remove moisture from the body, filter screens, and front air chamber. Note: Drain auxiliary water tank when the ambient temperature is below 30°F (0°C).
- f. Next remove the air chamber clean out covers, crack open the tailgate and raise the body slightly when parking the unit overnight.

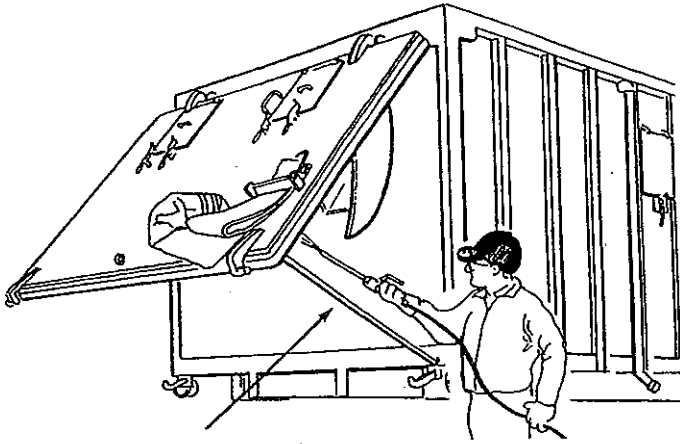

TAILGATE PROP

MAN0050

- 3. Cleaning The Body** - Clean and prime or paint exposed metal surfaces to prevent the formation of rust. This is particularly important on the inside walls, floor, and deflectors of the body.
- 4. Blower Bearing And Throw Out Collar Lubrication** - A good water resistant, lithium based, high temperature grease must be used. The central lubrication system must lubricate the bearings at the end of each work day or every 8 hours of continuous operation. Lubricate the bearings with the blower rotating slowly, this will eliminate air pockets which may lead to condensation and displace any moisture that may have accumulated.

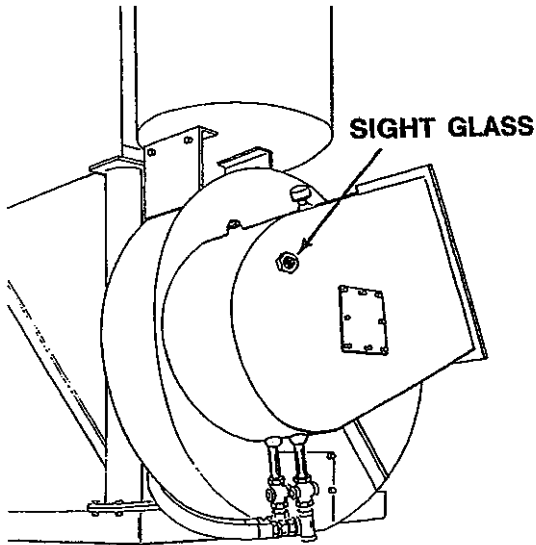

MAN0060

- 5. Checking Fluid Level (Daily)** – When checking the fluid level in the hydraulic tank insure that all cylinders are in their retracted position. The fluid level sight glass should be half covered. If low, fill the hydraulic tank with hydraulic fluid as specified in Specifications section. Note: When checking the fluid level note any frequent or sudden loss of fluid. This could indicate leakage, which must be traced and corrected to avert equipment failure and possible damage to components.

4.3 WEEKLY PREVENTATIVE MAINTENANCE

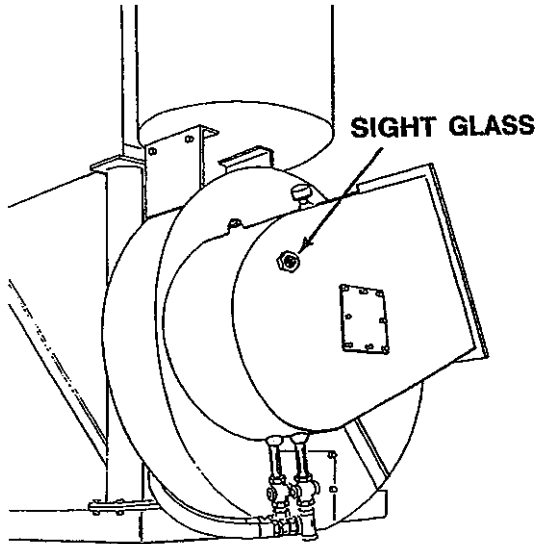

MAN0060

1. **Clean Tank Breather** – Clean the air breather every week. Replace a breather that cannot be cleaned adequately.

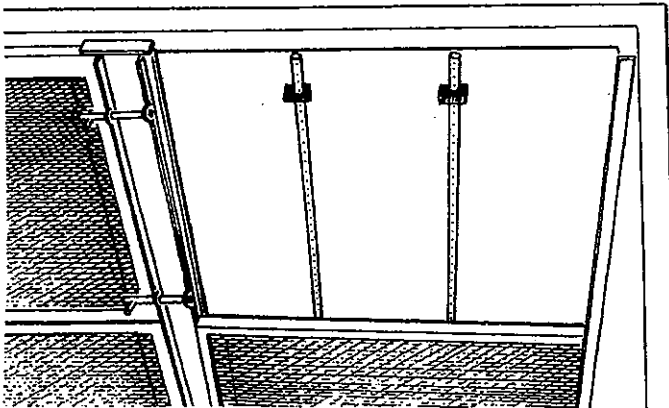

MAN0080

2. **Clean Body Filter Screens** – Each week completely remove the filter screens from the body and wash both sides of the perforated surfaces along with the screen tracks. To lower the screens from the body remove the cotter pins in the latch arms which support the screen in the center track. Move the latch arm out while supporting the screen, only far enough to remove one side of the screen.

Section 4 - Lubrication & Maintenance

Lower the screen to the floor and continue the process until all screens are removed from one side of the body. Continue in the same manner on the opposite side of the body until all screens are removed. Replace in reverse order as previously described.

3. **Lubrication** – Ensure the central lubrication system is lubricating the weekly grease points.

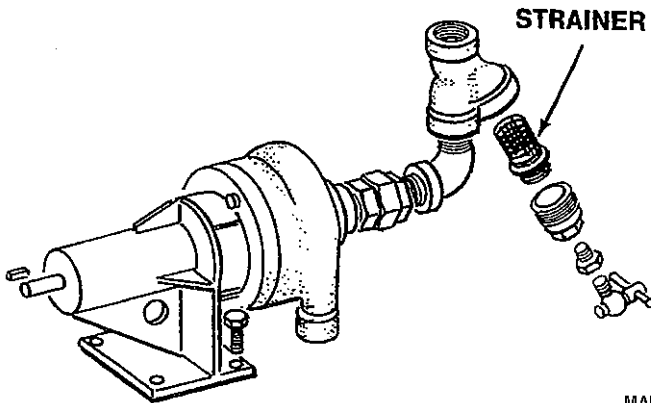

MAN0090

4. **Water Pump Strainer** – Remove the filter basket located in the “Y” strainer of the water pump feed; clean, and reinstall.

5. **Body Hoist**

- Inspect upper and lower trunnion ends of cylinder, at cylinder and lifting lever cross shafts, at frame, at valve and at pump.
- Inspect all hose lines for damage and hose ends for tightness
- Check valve control for proper shifting.
- Inspect seals in control valve.
- Check cylinder packing (a light film of fluid on the piston rod is acceptable).

6. Silencer Inspection

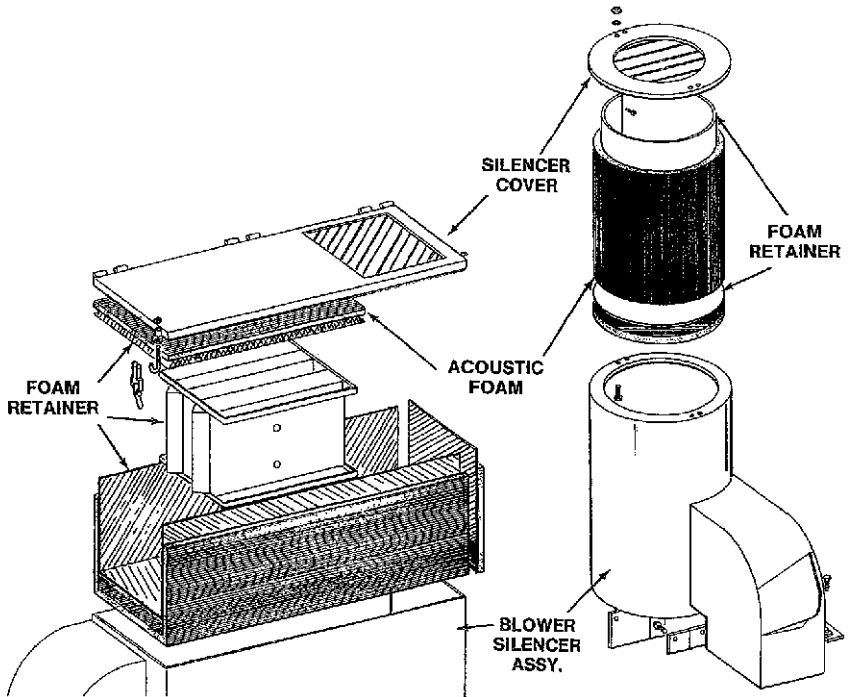

MAN0100

The silencer assembly consists of an outer steel shell lined with acoustic foam retained by perforated metal. To maintain maximum effectiveness of the silencer, periodic inspection and cleaning must be performed. The frequency of cleaning will depend upon the number of hours in use and the amount and type of material ingested into the silencer.

Cleaning Procedure:

The acoustic foam must be removed from the silencer for cleaning. Remove the silencer cover and retaining nuts. Remove the screws from the seam of the internal perforated sheet metal retainer and remove the retainers and foam. Remove the lower perforated retainer and foam.

The cleaning method used to clean the foam will depend on the trapped material. A mild soapy water solution can normally be used for washing the acoustic foam unless the material plugging the foam will harden when it comes in contact with water such as cement or fly ash. Alternate methods that can be used in these cases are blowing compressed air or vacuum cleaning. Clean the inside of the silencer shell by washing with water or vacuum cleaning. A wire brush or scraper may be needed to remove any "caked" dust. Repaint the inside of the silencer if bare metal is present.

Section 4 - Lubrication & Maintenance

Silencer Assembly:

Be sure the inside of the silencer is free from dirt and completely dry before installing the acoustic foam. To install, reverse the removal procedure.

Acoustic Foam Replacement:

If the foam has become unserviceable through deterioration, it must be replaced. When ordering replacement acoustical foam and retainers refer to the parts list to ensure correct parts.

- 6. Check Air Access Areas** – Check all intake hoses, nozzles, and deflectors for wear. Also check for tight connections between intake couplers, nozzles, ball joints, etc. Air leaks will reduce the efficiency of the blower.

- 7. Electrical System**– Check electrical wiring and insulation for frays, breaks, corrosion, and loose connections.

4.4 MONTHLY PREVENTATIVE MAINTENANCE

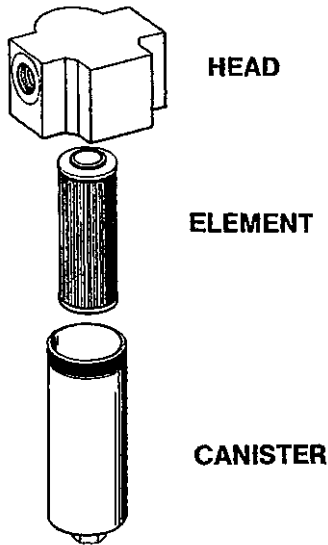

MAN0110

1. **Hydraulic Filter** – Once a month, change the hydraulic filter(s) if your unit is so equipped.
 - a. To remove the filter element, unscrew the filter canister from the filter assembly head and remove the filter element. Discard filter element, place a new element in the canister and secure canister to the filter assembly head. **Note:** *Do not over tighten.*

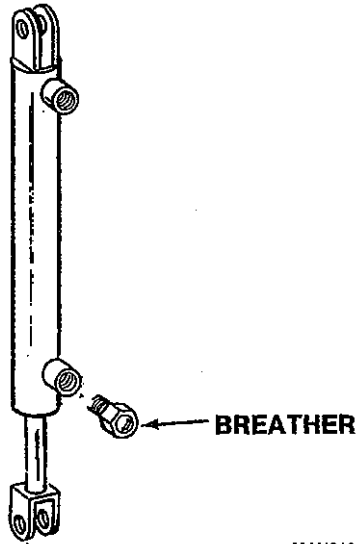

MAN0120

- 2. Cylinder Breathers** – Each month check the air breather located on the boom lift cylinders. If plugged replace with a new breather.

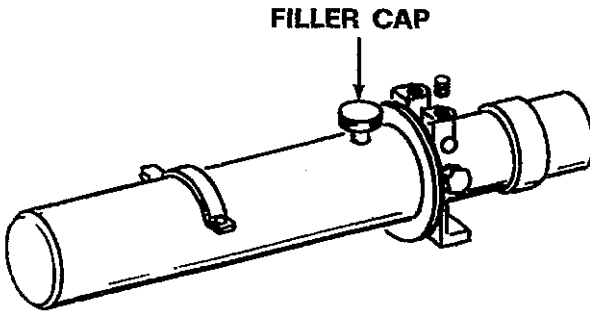

MAN0130

- 3. Power Boom Fluid Level** – Check hydraulic fluid level in the boom lift cylinder hydraulic circuit. The fluid level should be within one (1) inch of the filler cap. Cylinder must be fully retracted for accurate reading. **Note:** *This electric over hydraulic package is located on top of the debris body. If the unit is equipped with an engine driven power boom refer to the daily preventative maintenance schedule described earlier in this section.*

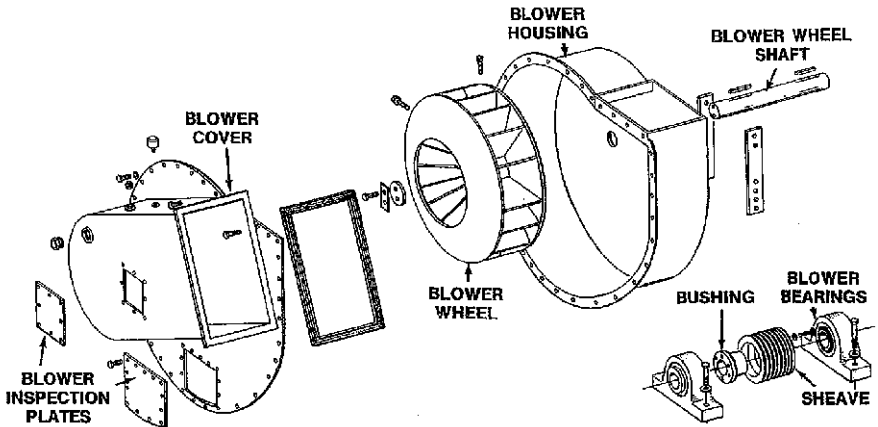

MAN0140

- 4. Blower** – Blower inspection is essential for safe, dependable and economical operation. The blower should be inspected monthly when used in normal service. More frequent inspection is necessary when the Vacall is used in severe or abrasive conditions. The blower requires little maintenance except lubrication of the blower bearings and inspection of the blower wheel. Periodic cleaning of the blower wheel will insure good balance and increased bearing life.

CAUTION

OAN0340

If unusual vibration or noise occurs, stop the blower immediately.

Inspection Procedure:

- Start the auxiliary engine and raise the debris body. Secure the body with the body prop
- Shut down the auxiliary engine, remove the key from the ignition switch, attach a "Do Not Operate" tag to the auxiliary ignition and steering wheel, and remove the auxiliary engine battery cables.
- Remove the blower wheel inspection plates located on the blower housing and intake duct.
- Inspect the blower wheel and inside of the blower housing for possible buildup of foreign material. Steam clean when required.

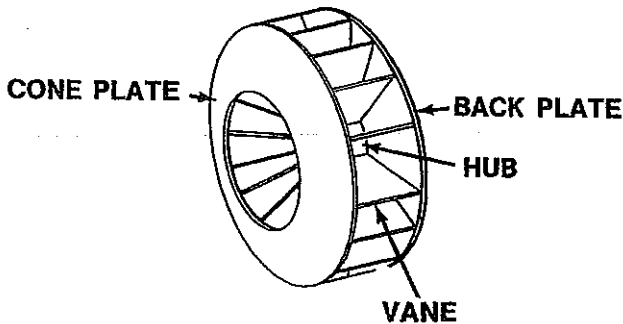

MAN0150

- e. Inspect the complete blower housing and wheel for possible cracks, wear, and corrosion. Inspect back plate, cone plate, hub, welds and vanes. Inspection for cracks should be completed with the use of a visual aid such as Diecheck. Any cracks, however minute, will require a replacement blower wheel. **Note:** *If more than 3/16" of wear is evident on the vane, cone plate, or back plate the blower must be replaced.*
- f. Upon completion of the inspection reinstall the blower inspection plates on the housing.
- g. Reinstall auxiliary engine battery cables.
- h. Start the blower engine, lower the body props then lower the body.
- i. Inspection of the dynamic balance condition of the blower wheel may be required. If vibration instrumentation is not available, a professional service should be employed to balance the blower assembly which is accomplished by rotating the blower at full speed and measuring the vibrational displacement and frequency at the blower bearings. The recommended maximum vibrational displacement is 1.0 mils at approximately 50 cycles per second (CPS). Do not exceed 2.0 mils at 50 CPS. Rebalance blower wheel when required.



OW0021

Never balance a unit that has the inspection covers removed from the blower housing.

Section 4 - Lubrication & Maintenance

5. **Check Blower Belt Adjustment** – Each Month of operation the matched set of blower drive belts should be checked and adjusted as necessary. Proper belt tension is obtained when the belts are depressed in the center with each belt requiring 16 lbs of force for used belts and 18 lbs of force for new belts to deflect 1/4 inch. **Note:** A belt tension gauge (P/N 9877-0005) is available from Vacall

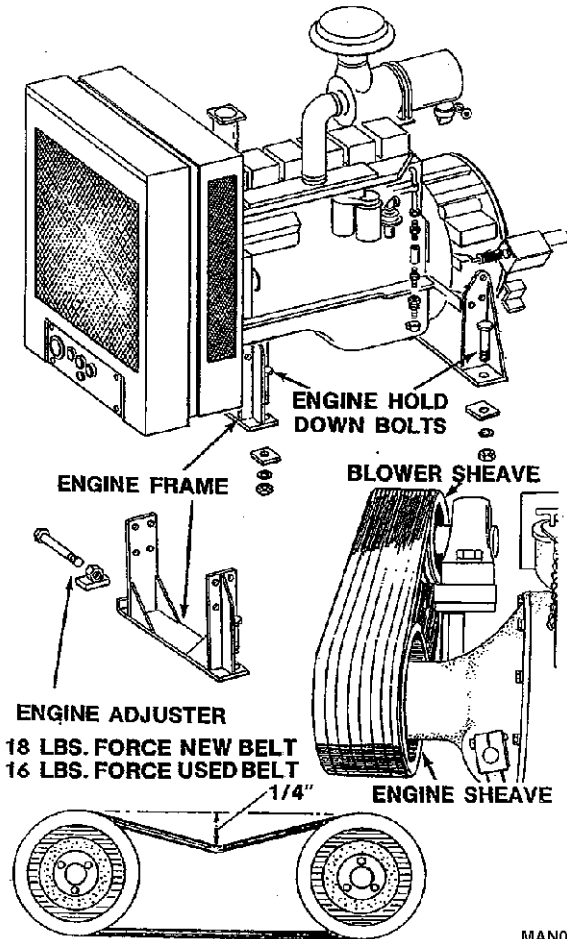

MAN0160

- To adjust the tension, loosen the four (4) engine hold down bolts at the engine frame just enough to slide the engine.
- Remove the belt /bearing guide.
- Move engine to tension belts by means of two (2) engine adjusters at engine frame. Moving the engine forward will decrease the tension on the belts and moving it rearward will increase the belt tension.

Section 4 - Lubrication & Maintenance

- d. Make certain that the engine and blower sheaves are perfectly aligned. Use a straight edge to check sheave alignment by placing it along the sheave faces.
- e. Once tension and alignment are achieved tighten the four (4) engine hold down bolts and replace the belt/bearing guard.

6. Intake Hose

Intake hoses are made of rubber and fabric and wear should be expected. This wear can be kept to a minimum by employing a few good operation and maintenance practices.

- Inspect the hose frequently to determine where the most wear is occurring.
- Rotate the hose periodically to reduce the wear in one spot. Rotating the hose 180 degrees, 90 degrees, and end over end periodically will improve the life.
- Minor cracks, punctures, and other leaks should be repaired as soon as they are detected to prevent enlarging to a point where they cannot be repaired. A repair kit is available.
- Proper spacing of the support collars insures proper bending radius. Refer to the illustration for proper spacing of support collars.

7. Hydraulic System Service

Contamination

Many hydraulic problems may be traced directly to the fluid. It is important that all foreign matter be kept from the hydraulic fluid. Invisible quantities of abrasive type contamination may cause serious pump wear, malfunctioning of pumps and valves, and sludge accumulations within the system in relatively short periods of time. It is also essential that moisture and water be kept from the hydraulic fluids and system.

Commercial Hydraulic Fluid Testing

Hydraulic fluid samples should be taken periodically for laboratory analysis. The actual sampling method is critical. It should be done based on ANSI Standard B93.19M(R1980). This standard is available from the National Fluid Power Association, 3333 N. Mayfair Rd, Milwaukee, WI 53222

Samples should be taken from the center of the reservoir when the fluid is at operating temperature and placed in a clean, dry, glass bottle with a non-shedding, screw-on cap. The bottle should be labeled with the date, type of fluid, and model and serial number of the machine.

Two identical samples should be taken. One for laboratory analysis and one for your own preliminary analysis while you are waiting for the lab report.

We recommend the use of commercial laboratory services for analysis of routine fluid samples taken on a regularly scheduled basis. The most important analysis are particle count, Spectro-chemical analysis, water content, and viscosity.

In House Hydraulic Fluid Testing

After your sample has been allowed to stand for 20 to 30 minutes to eliminate all air bubbles, hold the bottle up to the light to check for debris in the fluid and also check whether the fluid is clear or cloudy.

Any visible debris is an indication of a severe solid contamination problem, the source of which must be located and corrected immediately. Common sources of this kind of contamination may be component wear, unsealed reservoir cover, or dirty air breather filters.

If the sample is the least bit “cloudy” it may be an indication of water contamination, the source of which must be located and corrected immediately. Common sources are inadequate outdoor storage, unsealed reservoir covers or condensation.

A “Blotter Spot Test” may also be performed to test for oxidation. Place a drop of fluid on a piece of white blotter paper (P/N 102480).

Note: *The blotter test will provide an indication that a more complete test may be necessary.*

- If the blotter remains colorless or develops only a light yellow ring, oxidation is under control.
- If color develops but is uniform throughout, the fluid is still serviceable but should be checked for correct additive content.
- If the sample shows distinct rings, the fluid should be changed.
- If a distinct dark spot remains in the middle, but a lighter color fluid migrates outward in the blotter paper the fluid is about to dump sludge or other by-products into the system. The time for replacement of this fluid has already passed.

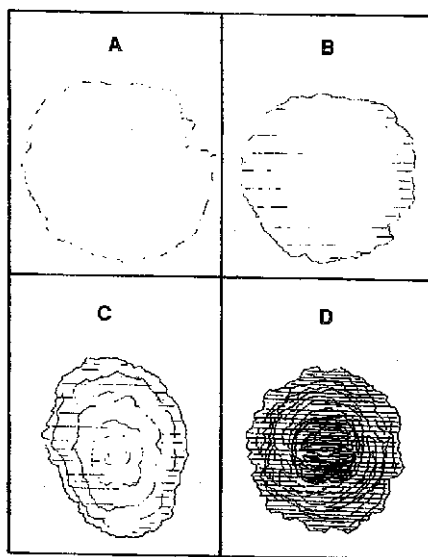

MAN0170

Section 4 - Lubrication & Maintenance

Kits are available from your fluid supplier to test for acid content. A shift in acid content may indicate a breakdown in the fluid.

KEEP ACCURATE DATED RECORDS OF ALL PERTINENT INFORMATION GAINED FROM THESE TESTS.

4.5 YEARLY PREVENTATIVE MAINTENANCE

1. Flushing Hydraulic System

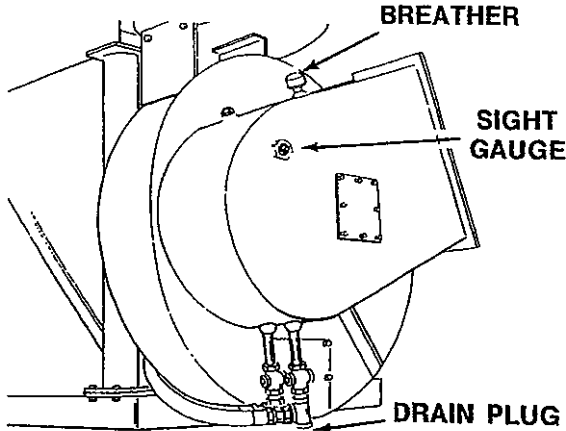

MAN0180

- a. Annually drain all fluid from the hydraulic tank. **Note:** To drain the hoist, the body must be fully raised and securely blocked. Remove the vent plug on the top side of the cylinder. Lower the line at the rod end of the cylinder, or remove the pipe plugs at the upper and lower ends of the cylinder, and drain the fluid into a suitable container. Also lower both lines at the pump, or remove the pipe plug in the side of the housing and drain the fluid into a suitable container. Move the valve control lever in the cab back and forth several times so that any trapped fluid will be drained from the system. Drain the hydraulic fluid reservoir by removing the drain plug.
- b. Fill the hydraulic tank with fresh fluid as specified in the Specifications section.
- c. Start the Vacall engine and operate all the hydraulic functions as described in the Operator's Manual. Leave all the hydraulic cylinders in the retracted position and shut down the unit.
- d. Recheck the fluid level and add fluid as necessary to bring the level to half way in the sight gauge.
- e. Replace the hydraulic tank air breather.
- f. Replace the fibrous hydraulic cylinder air breathers.

Section 4 - Lubrication & Maintenance

2. Seasonal Storage

If the Vacall is going to be inactive for long periods of time, or stored, take the following steps to avoid corrosion in the body and air chamber.

- a. Steam clean or sandblast the inside of the body, air chamber, blower housing, and blower.
- b. Repaint with a good primer such as Rustoleum to prevent any corrosive action due to moisture.

3. Blower Drive Engine Preventative Maintenance

Refer to the auxiliary engine manufacturer's service manual for recommended maintenance and checks.

4.6 LUBRICATION POINTS

Ensure the central lubricating system is lubricating the unit at intervals indicated or more frequently in severe or dirty operations.

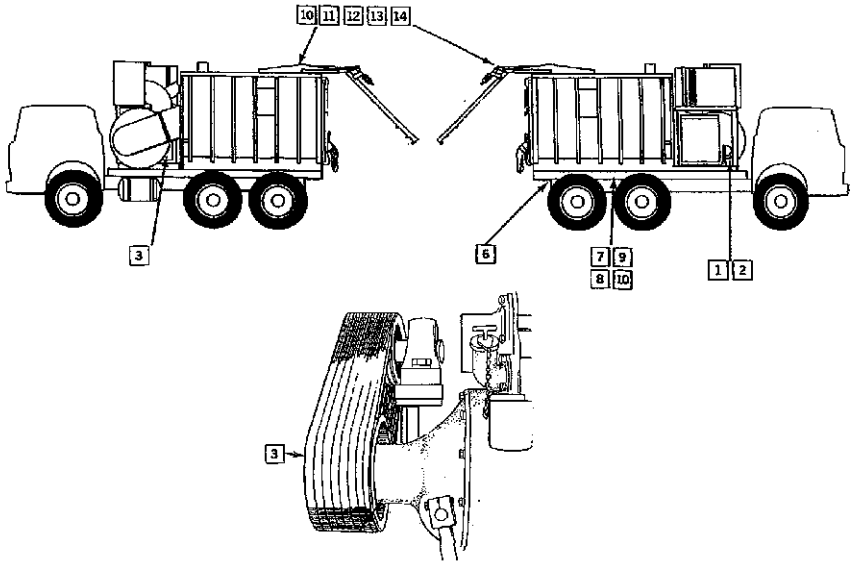

MAN0190

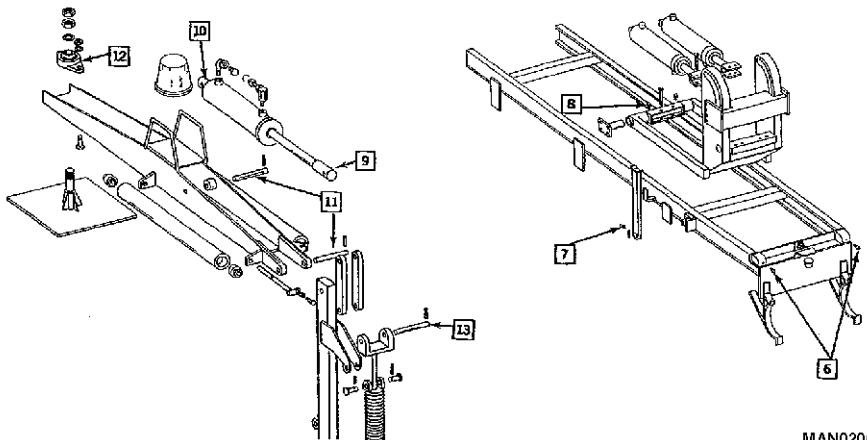

MAN0200

Section 4 - Lubrication & Maintenance

Location	Description	No. Of Lube Fittings	Lube Interval Hours
3	Pilot Bearing	1	100
6	Body Hoist Rear Hinge	2	40
7	Body Prop	2	40
8	Body Hoist Cylinder, Lower End	3	40
9	Power Boom Cylinder, Upper End	1	40
10	Power Boom Cylinder, Lower End	1	40
11	Power Boom Arm	1	40
12	Power Boom Center Pin Bearing	1	40
13	Power Boom Front Spring Bushing	1	40

Note: Note: Refer to Engine and Clutch Manual for remainder of lubrication instructions.

SECTION 5 - SPECIFICATIONS

5.1 PRODUCT SPECIFICATIONS

Lubricants

Oil..... SAE #10 or equivalent
Grease..... Multiservice (quantity grade)
(High temperature lithium base blower bearings and throw out collar only)

Hydraulic System

(Approximate capacity)

Fluid tanks21 gallons
Oil..... Mobil 424 or equivalent
System pressure settings Main Valve - 2200 psi/Ardevak Valve - 600psi
Type of fittings Steel tubing with brazed and flared fittings: reinforced rubber hose with crimped full flow fittings, o-ring fittings
Filtration..... Pressure and return line disposable filter element(s)

Pump

Type.....Positive displacement; gear pump driven by auxiliary engine
Capacity(Single Section) 12gpm @ 2200 rpm

Hydraulic fluid

To serve its purpose and give long and satisfactory service, hydraulic fluid must possess desirable physical and chemical characteristics. Stability over a wide range of temperatures and under agitation is very important. Premium hydraulic fluids should be used in Vacall hydraulic systems. In addition to the above characteristics select additives should be added to provide additional resistance to wear, corrosion, oxidation, decomposition, and foaming. All additive blending should be done by the lubricant supplier so they are compatible with each other. A reputable lubricant supplier backed by a reputable oil company is great assurance of obtaining high quality products.

Section 5 - Specifications

Hydraulic Fluid Recommendation

All Vacall hydraulics systems are factory filled with a high quality anti-wear hydraulic fluid meeting an ISO 32 specification. On units put into service where there are high ambient temperatures or sustained high duty cycles, it may be desirable to change the fluid to an ISO 46 specification (higher viscosity). In colder climates or light duty cycles, an ISO 22 might be more appropriate.

GRADE ISO/VISCOSITY	22	32	46
AGMA NO.....			1
Gravity, API.....	33	31	31
Flash, °F.....	375	380	390
Pour Point, °F.....	-20	-20	-20
Viscosity:			
SSU @ 100° F.....	112	158	228
SSU @ 210° F.....	40	44	48
cSt @ 40° C.....	21	30.5	44
cSt @ 100° C.....	4.1	5.2	6.5
Viscosity Index.....	98	99	99
ASTM Oxidation Test (Hours to 2.0 Neut. No.).....	2500	2500	2500
ASTM Rust Test, A & B.....	Pass	Pass	Pass
Foam Test.....	Pass	Pass	Pass
Vickers Vane Pump Test.....	Pass	Pass	Pass
Dielectric Strength (ASTM 877) EC # @ 180° F.....	25Kv	25Kv	25Kv
	40-37-3(10)	40-37-3(15)	40-37-3(15)

























































































































































































































































































































MAN0330

CAUTION

OAN0340

Do not use engine oil, automatic transmission fluid (ATF), or add diesel fuel or kerosene to the hydraulic fluid. The service life of all hydraulic system components may be adversely affected.

Capscrew Marking and Torque Values

Usage	Much Used	Much Used	Used at Times	Used at Times
Capscrew Diameter & Minimum Tensile Strength PSI	To 1/2-69,000	To 3/4-120,000	To 5/8-140,000	150,000
	To 3/4-64,000	To 1-115,000	To 3/4-133,000	
Quality of Mat'l	Indeterminate	Min. Commercial	Med. Commercial	Best Commercial
SAE Grade Number	1 or 2	5	6 or 7	8
CAPSCREW HEAD MARKINGS				
Manufacturer's marks may vary. These are all SAE Grade 5 (3-line).				
				
				
				
				
				
				
				
				
				
				
				
				
				
				
				
				
				
				
				
				
				
				
				
				
				
				
				
				
				
				
				
				
				
				
				
				
				
				
				
				
				
				
				
				
				
				
				
				
				
				
				
				
				
				
				
				
				
				
				
				
				
				
				
				
				
				
				
				
				
				
				
				
				
				
				
				
				
				

This Page Intentionally Left Blank

A	Hydraulic Fluid 5-1
Advanced Boom Operation 3-6	J
Auxiliary Engine Control Panel & Gauges 2-7	Job-Site Hazards 1-6
Auxiliary Engine Operation 3-1	Joystick Enclosure 2-9
Auxiliary Engine Shut Down 3-5	L
B	Left Hand Joystick Functions 2-10
Biological Hazards 1-11	Lubricants 5-1
Boom Controls 2-9	Lubrication & Maintenance 4-1
Burn Hazards 1-3	Lubrication Points 4-19
C	M
Cab Control Box & Gauges 2-4	Monthly Maintenance 4-9
Chemical Hazards 1-10	Blower 4-11
Chemical Waste Hazard 1-11	Blower Belt Adjustment 4-13
Cleaning Debris Body 3-12	Cylinder Breathers 4-10
Control Box Ignition 2-6	Hydraulic Filter 4-9
Controls & Indicators 2-4	Hydraulic System 4-14
Crush Hazards 1-4	Intake Hose 4-14
D	Power Boom Fluid Level 4-10
Daily Maintenance 4-2	N
Blower Bearing & Throw Out Collar Lubrication 4-3	Nozzle Auto Swing Function 3-7
Checking Fluid Level 4-4	P
Cleaning the Body 4-3	Personal Protection Equipment 1-15
General Cleaning 4-2	Pre-Operation and Controls 2-1
Inspection 4-2	Pre-Operation Checks 2-1
Decals 2-2	R
Dumping a Load 3-10	Rear Boom Pendant 2-12
Dust Hazard 1-12	Right Hand Joystick Functions 2-11
E	S
Electrical Hazards 1-2	Safety Practices 1-1
End of Shift Shutdown 3-13	Safety Signal Words 1-1
F	Sewer Gas Hazard 1-11
Fire/Explosion Hazards 1-2	Slip and Fall Hazard 1-6
H	Specifications 5-1
High Pressure Hazards 1-8	T
	Tailgate Latch (Manual) 2-13

Index

Tip Over Hazard 1-6
Travel Hazards 1-7

W

Water Hand Gun..... 3-8
Water System 3-8
Water Tank Fill 3-9
Weekly Maintenance 4-5
 Air Access Areas..... 4-8
 Body Hoist..... 4-6
 Cleaning Body Filter Screens..... 4-5
 Cleaning Tank Breather 4-5
 Electrical System..... 4-8
 Lubrication..... 4-6
 Silencer Inspection..... 4-7
 Water Pump Strainer..... 4-6

Y

Yearly Maintenance..... 4-17
 Auxiliary Engine 4-18
 Flushing Hydraulic System..... 4-17
 Seasonal Storage..... 4-18

VACALL™

VacAll Industries, Inc.

406 Mill Ave SW

New Philadelphia OH. 44663

USA

Phone: (330) 339-2211

Customer Support Toll Free: (800) 445-4752

Fax: (330) 339-3579
